

CONTROL FOCUSED • TECHNOLOGY DRIVEN

5000 VALVE SERIES

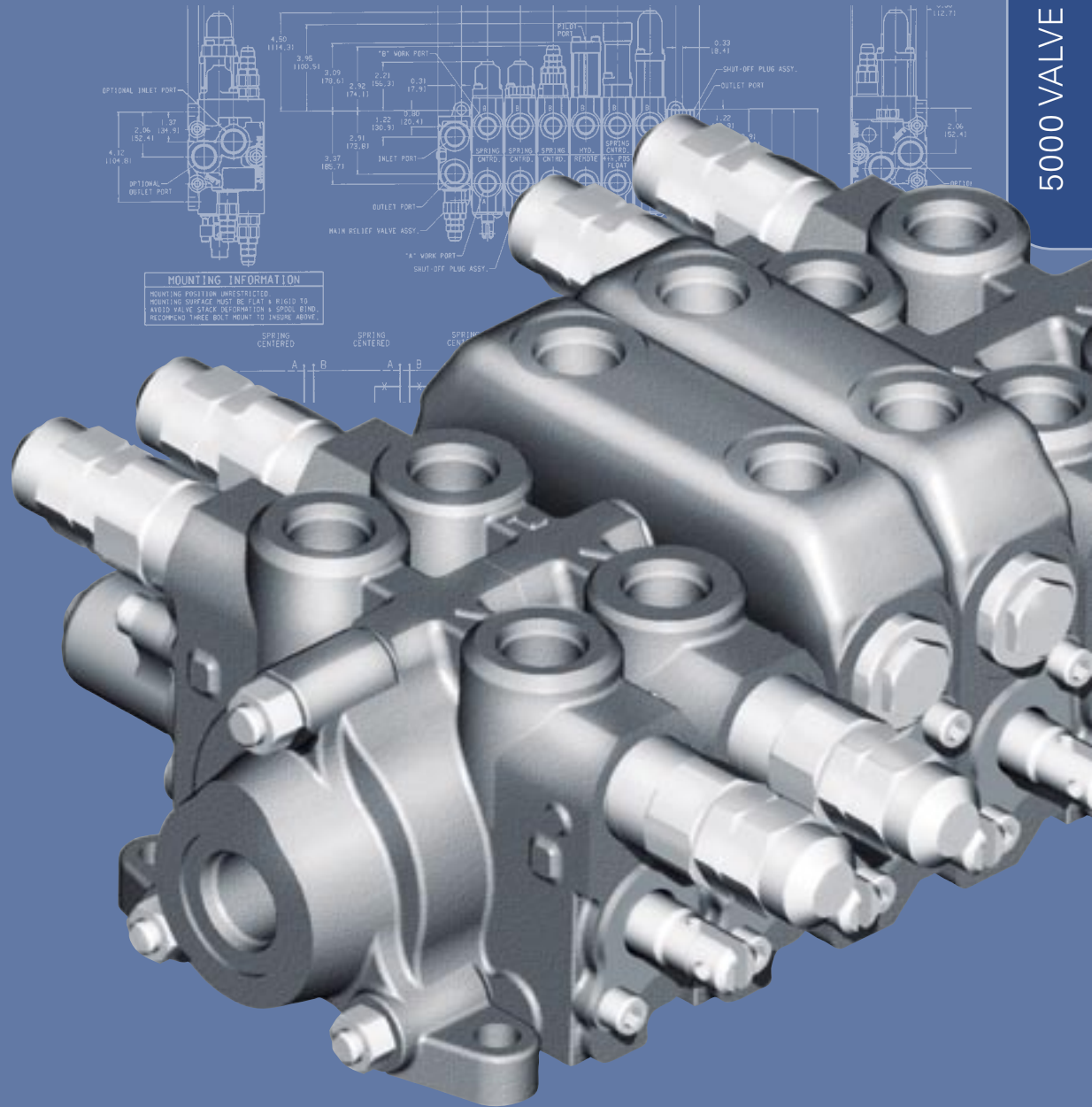

MODEL 5000 SECTIONAL VALVE

MODEL 5000 SECTIONAL CUTAWAY

INLET/OUTLET SECTION CUTAWAY

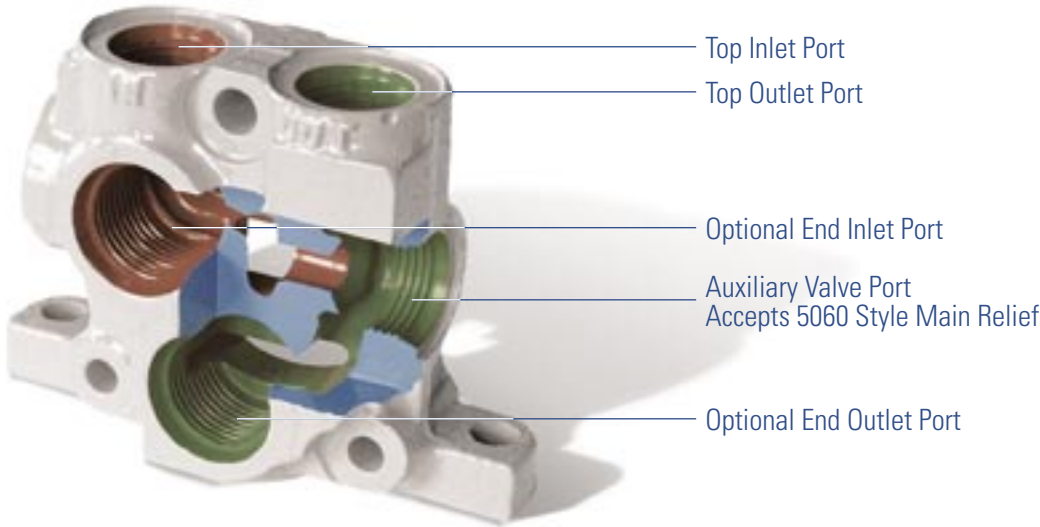

PARALLEL CIRCUIT SPOOL SECTION CUTAWAY

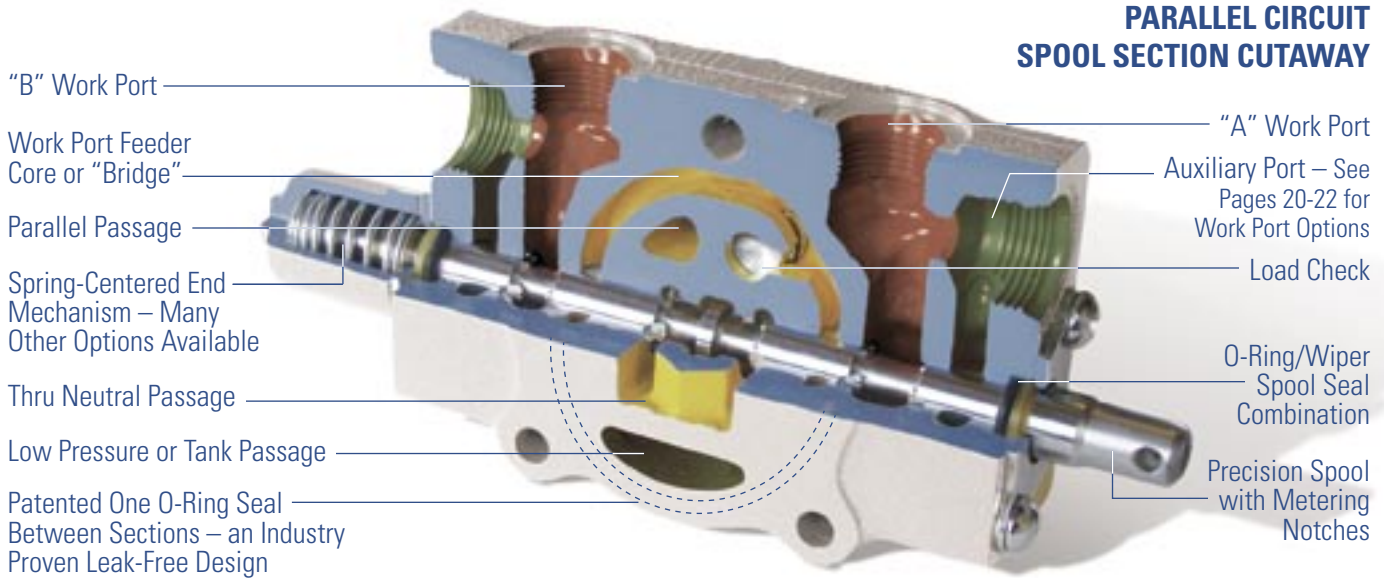

UNIVERSAL OUTLET/ POWER BEYOND SECTION CUTAWAY

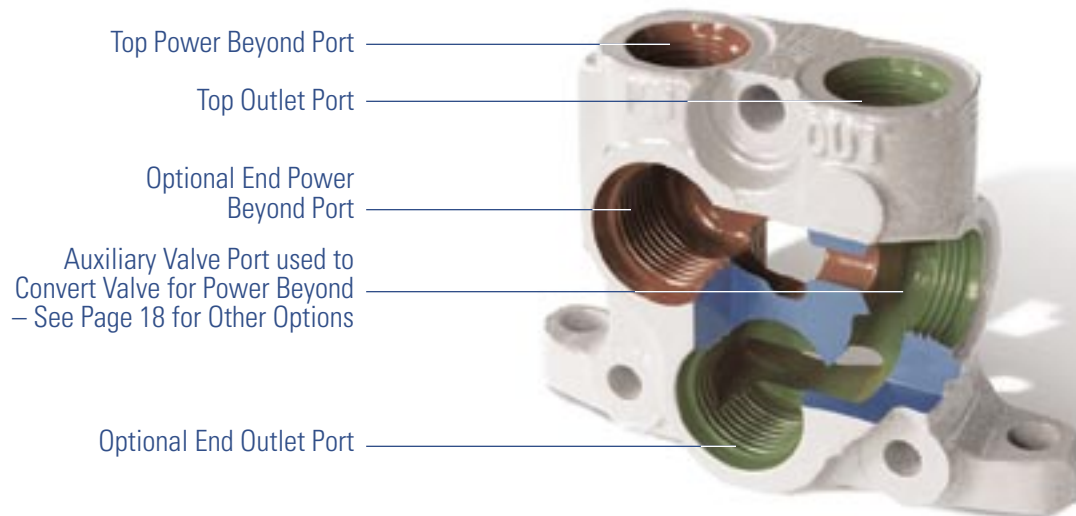

MODEL 5000

Since 1946, HUSCO International has established itself as the resource OEM engineers rely on for help designing high quality, innovative, customized products that meet precision motion control requirements. This catalog fully illustrates the component features and options you need to specify, build and service a Model 5000 sectional body directional control valve.

Designed for hydraulic systems, the Model 5000 valve line is made from an assortment of valve component sections and options that deliver the desired control valve circuit to match your specific application.

FEATURES

- 3000 psi operating pressure rating (207 bar)
- Open-center or closed-center operation
- Hard chrome plated spools
- Load check in each section
- Single “low pressure” O-ring sealing between sections
- Precision spool with metering notches

OPTIONS

- High pressure carryover (Power Beyond)
- Lock-out spool section (Built-in pilot operated check valve section)
- Mid-inlet flow combiner or separator
- Left-hand spool sections*
- Parallel, Conventional and Series circuitry
- End mechanisms:
 - Spring centered
 - Detent – single or multi-position
 - 4th position float
 - Hydraulic remote
 - Pneumatic remote
 - Automatic kick-out
- Auxiliary valves:
 - Pilot-operated, anti-cavitation check combination; relief cartridges
 - Anti-cavitation; cartridges
- Regenerative spools*
- Specialized spools*

* Consult HUSCO

Features and Options	3
Pressure Drop Curves	5
Technical Data	5
Dimensional Data in Inches (Millimeters)	6
Inlet End Section Assemblies (L.H. Covers)	7-10
Inlet Sections	7
Inlet/Outlet Sections (cutaway photo pg. 19)	8
Mid-Inlet Sections	9-10
Spool Section Assemblies	11-17
Parallel Circuit Manually Operated Sections	11
Parallel Circuit Manually Operated Lock-Out Spool Sections	12
Parallel Circuit Hydraulic Remote Sections	13
Parallel Circuit Electric Sections	14
Conventional Circuit Manually Operated Sections (Tandem)	15
Series Circuit Manually Operated Sections	16
Outlet End Section Assemblies (R.H. Covers)	17-20
End Outlet/Turnaround Sections/Top Outlet	17
Power Beyond/Closed-Center Sections	17
Universal Outlet/Optional P.B. Sections (cutaway photo pg. 19)	18
Cutaway photo of Inlet P/N – and Outlet P/N	19
Relief Valve Assemblies	20-21
Auxiliary Valve and Tie Rod Information	22
Lever Assemblies	23-24
End Mechanisms ■ Service and Kit Information ■ Restrictors	25-27
Spring Ctr. ■ Detents ■ Detent/Float	25
Hydraulic Remote ■ Pneumatic Remote	26
Spring Ctr. With Detents: In and Out, In Only, Out Only ■ Flow Restrictors	27

APPENDICES

Appendix 1	Automatic Kick-Out Feature (ordering information pg. 15)	28
Appendix 2	Spool End Orientation/Cable Connectors	29
Appendix 3	Basic Casting Identification	29
Appendix 4	52250 Style Lever Parts Listing	30
Appendix 5	P.O. Relief and Anti-Void Operation	31
Appendix 6	P.O. Relief and Anti-Void Maintenance Procedure	32
Appendix 7	Valve Assembly Procedure	33
Appendix 8	Valve Assembly Specification Sheet	34

PRESSURE DROP CURVES AND TECHNICAL DATA

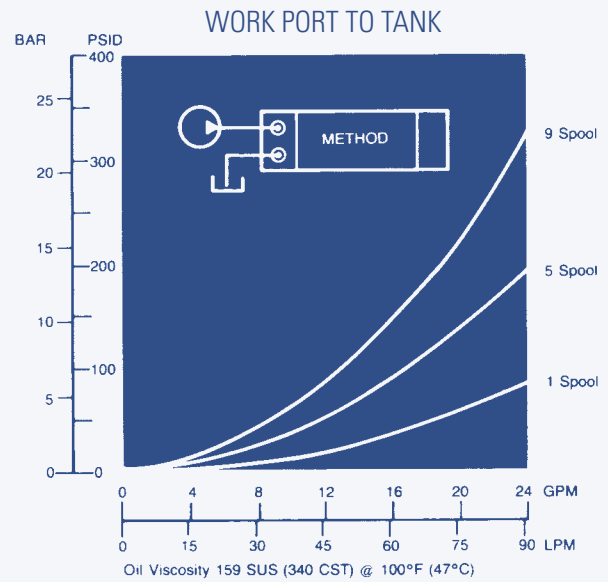
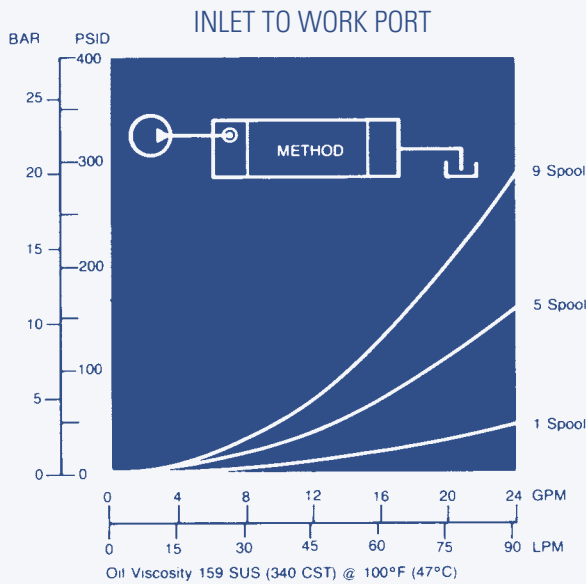
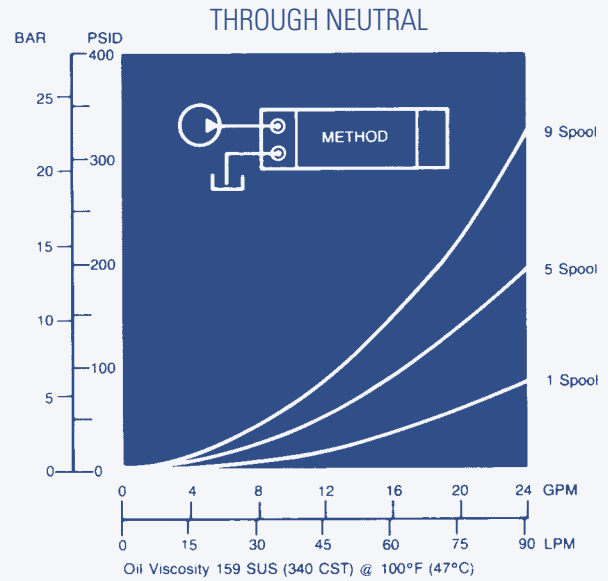
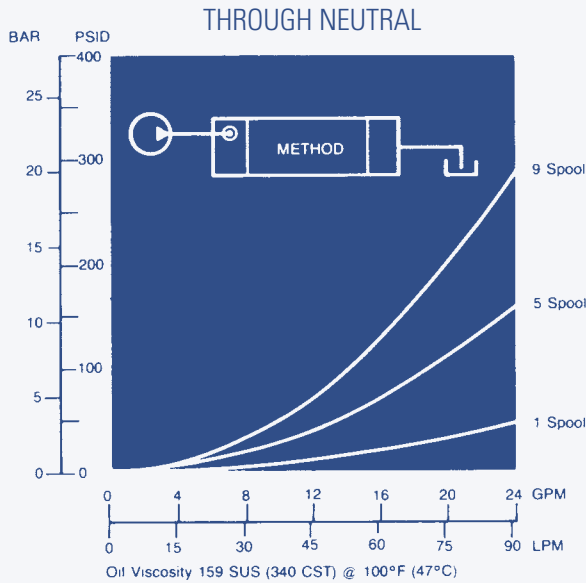

Flow rating (nominal) 20 gpm (75 lpm)
 Operating Pressure* 3000 psi (207 bar)
 (Method of verifying rated fatigue pressure of the pressure containing envelope conforms to NFPA Recommended Std., NFPA/2.6.1 – 1974 Category 1/90)
 * Higher pressure applications consult HUSCO

Seals Buna-N Standard
 Vitron Optional

Recommended Filtration ISO 20/18/13
 Maximum number of spool sections (any combination of) per valve assembly 11
 Maximum outlet port/tank core (return) pressure 500 psi

We reserve the right to amend these specifications at any time without notice. The only warranty applicable is our standard written warranty. We make no other warranty, expressed or implied.

Performance characteristics shown are typical of production units tested in the laboratory and are not necessarily representative of any one unit.

INLET SECTION ASSEMBLIES

WITH END PORT. NO AUXILIARY VALVE PORT OPTION (FOR APPLICATIONS THAT DO NOT REQUIRE A MAIN RELIEF VALVE AT THE VALVE ASSEMBLY)

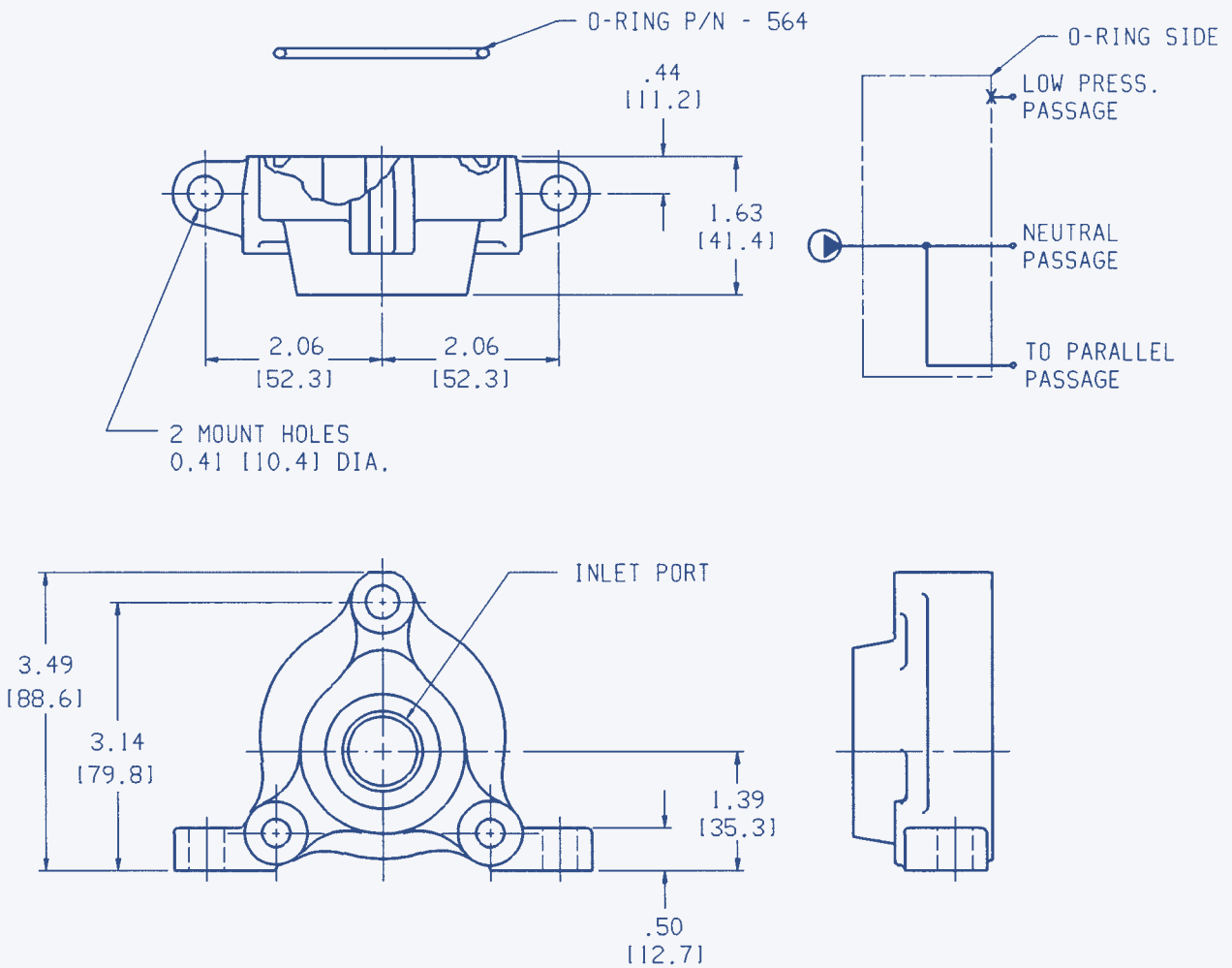

PORT SIZE	INLET SECTION PART NUMBER
SAE 10	5001-A35

USED IN SECTION ① OF THE VALVE ASSEMBLY SPECIFICATION SHEET

INLET/OUTLET SECTION ASSEMBLIES

WITH AUXILIARY VALVE PORT FOR MAIN RELIEF VALVE.
TOP INLET/OUTLET PORTS OPTIONAL END INLET/OUTLET PORTS.

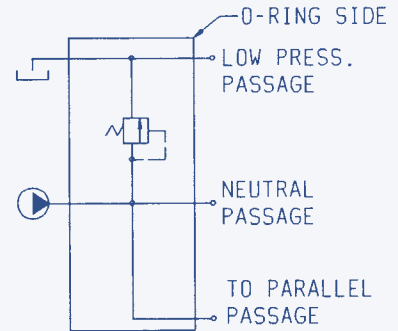
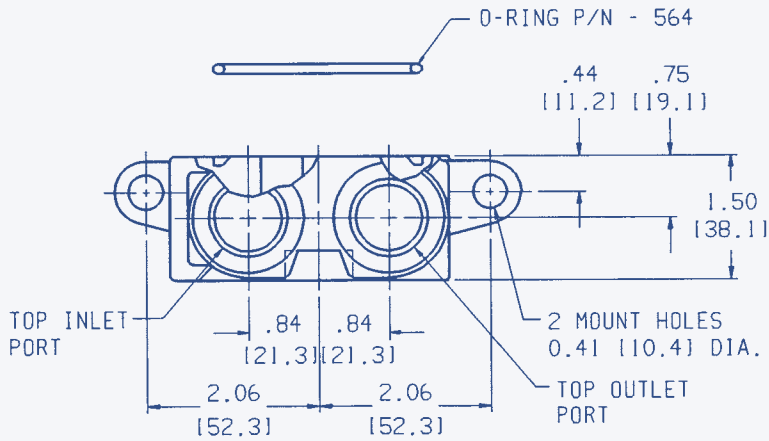

CIRCUIT SHOWN WITH R.V. INSTALLED
(R.V. SOLD SEPARATELY)

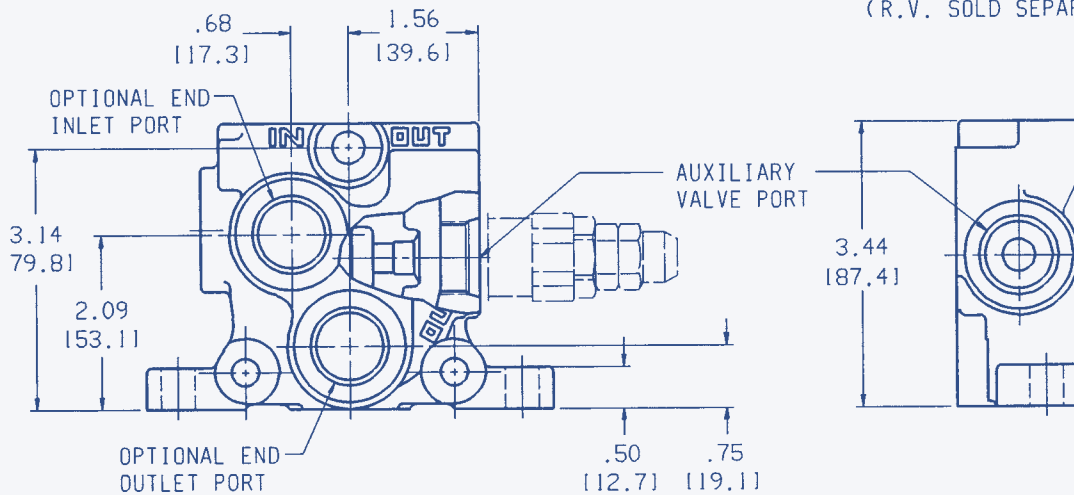

PORT SIZES				INLET SECTION PART NUMBERS
INLET		OUTLET		
TOP	END	TOP	END	
SAE 10	NONE	SAE 10	NONE	5001-A59
SAE 10	SAE 10	SAE 10	SAE 10	5001-A115
SAE 10	SAE 12	SAE 10	SAE 12	5001-A88

USED IN SECTION ① OF THE VALVE
ASSEMBLY SPECIFICATION SHEET

SEE CUT-AWAY PHOTO ON PAGE 19

MID-INLET COMBINER SECTION ASSEMBLY

MID-INLET PUMP FLOW COMBINES WITH UPSTREAM PUMP FLOW TO FEED DOWNSTREAM SPOOL SECTIONS. WHEN UPSTREAM SPOOL SECTIONS ARE ACTIVATED, DOWNSTREAM SPOOL SECTIONS ARE EXPOSED TO MID-INLET PUMP FLOW ONLY.

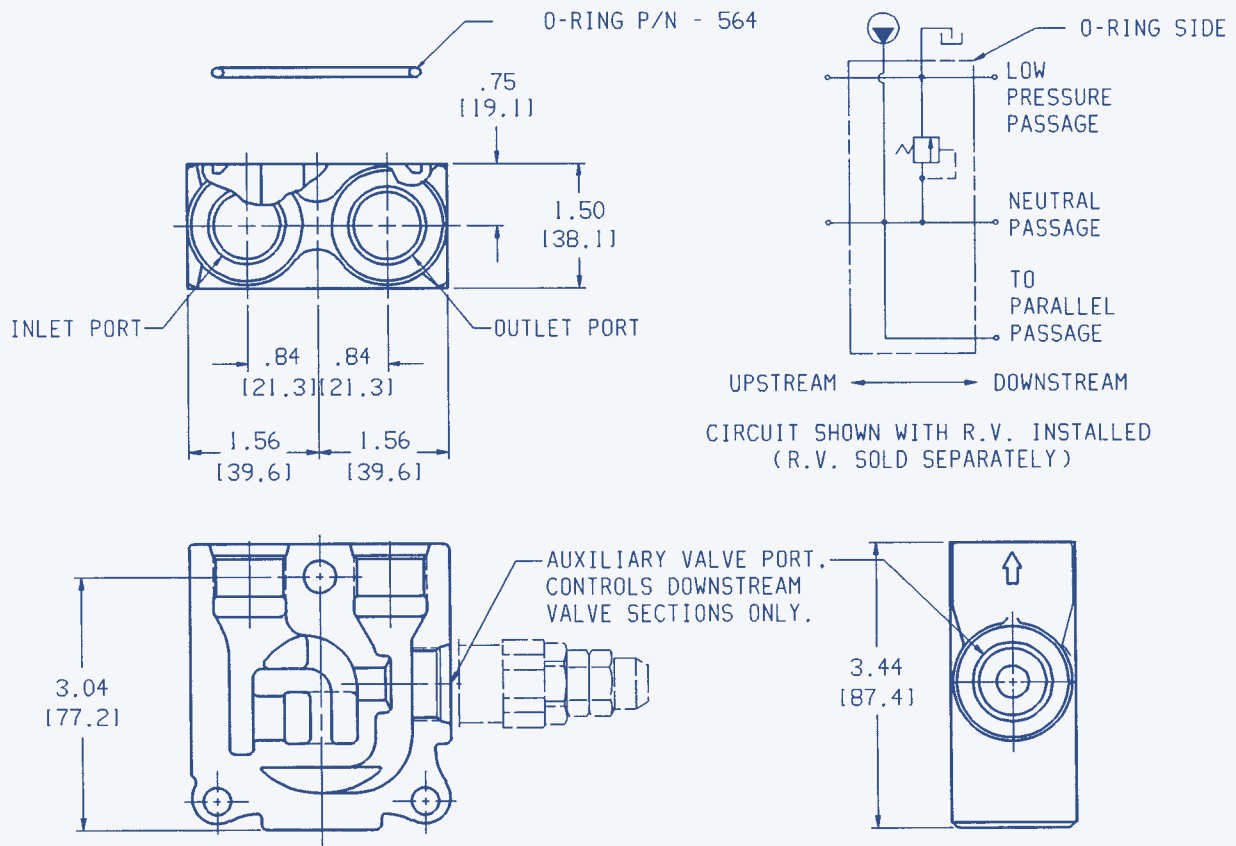

MID-INLET SECTIONS ARE USED IN-BETWEEN SPOOL SECTIONS EITHER TO ADD FLOW TO THE DOWNSTREAM SPOOL SECTIONS "COMBINER" OR TO INTRODUCE A "SEPARATE FLOW" CONDITION TO THE DOWNSTREAM SPOOL SECTIONS. MID-INLET SECTIONS ARE COUNTED AS A SPOOL SECTION WHEN DETERMINING TIE ROD KIT NUMBER.

PORT SIZES		INLET SECTION PART NUMBER
INLET	OUTLET	
SAE 10	SAE 10	5001-M15

USED IN SECTION ② OF THE VALVE ASSEMBLY SPECIFICATION SHEET

MID-INLET SEPARATE FLOW SECTION ASSEMBLY

MID-INLET PUMP FLOW FEEDS DOWNSTREAM SPOOL SECTIONS.
UPSTREAM PUMP FLOW TO LOW PRESSURE.

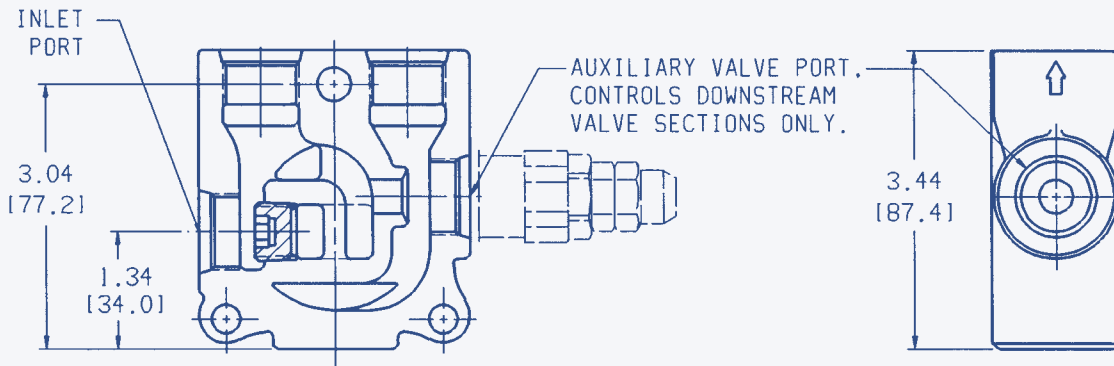
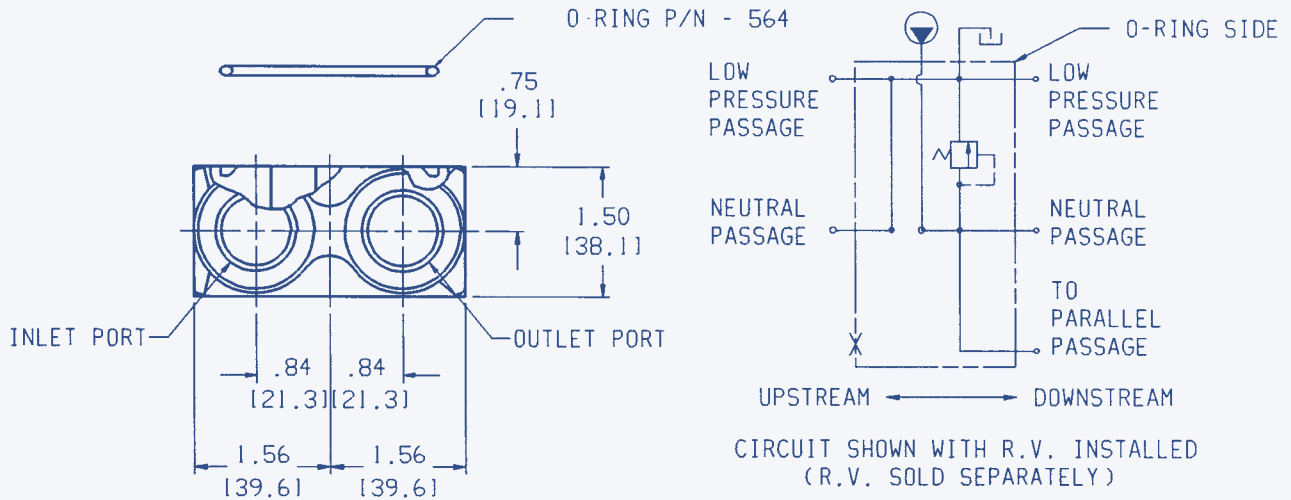

MID-INLET SECTIONS ARE USED IN-BETWEEN SPOOL SECTIONS EITHER TO ADD FLOW TO THE DOWNSTREAM SPOOL SECTIONS "COMBINER" OR TO INTRODUCE A "SEPARATE FLOW" CONDITION TO THE DOWNSTREAM SPOOL SECTIONS. MID-INLET SECTIONS ARE COUNTED AS A SPOOL SECTION WHEN DETERMINING TIE ROD KIT NUMBER.

PORT SIZES		INLET SECTION PART NUMBER
INLET (BOTH)	OUTLET	
SAE 10	SAE 10	5001-M16

USED IN SECTION ② OF THE VALVE ASSEMBLY SPECIFICATION SHEET

PARALLEL CIRCUIT MANUALLY OPERATED SPOOL SECTION ASSEMBLIES

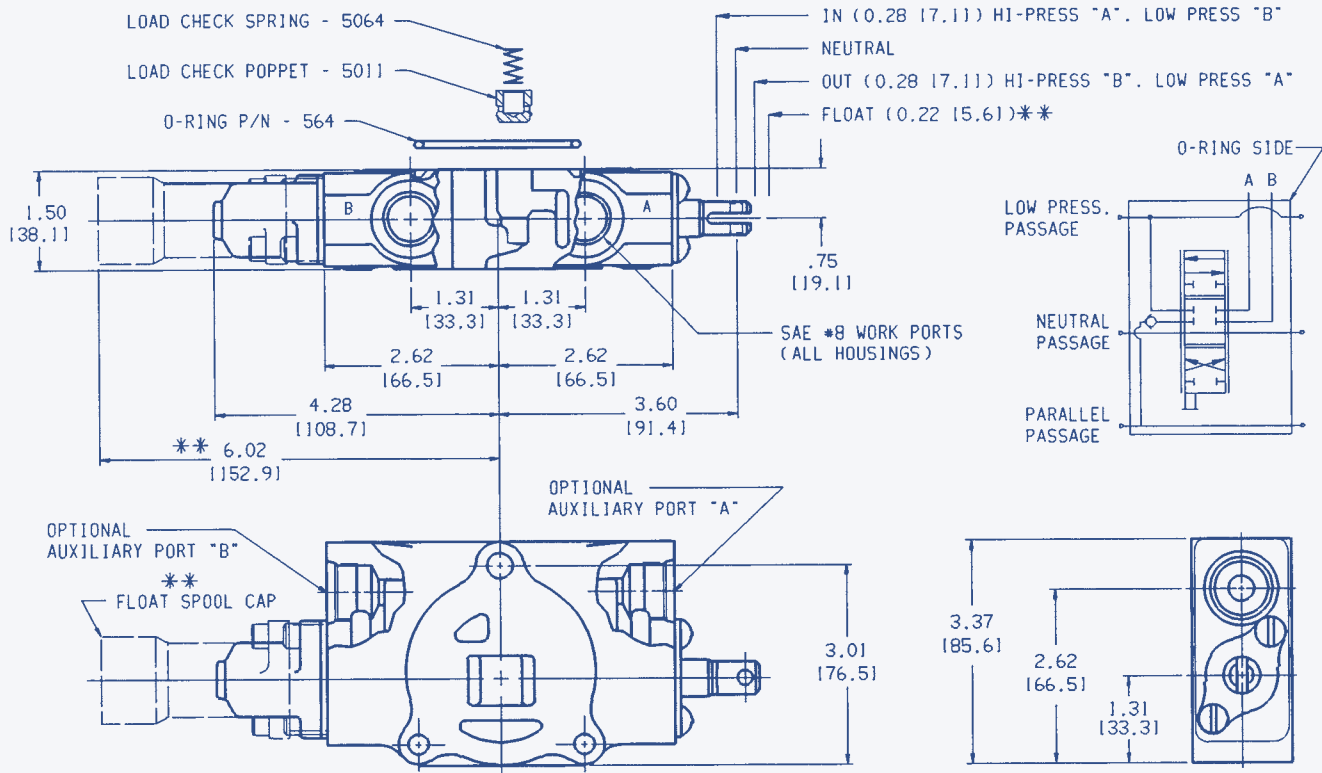

3 POS. - 4 WAY			SPOOL SECTION ASSY. PART NUMBERS	
SPOOL AND END MECHANISM IN → OUT	SPOOL P/N:	END MECHANISM KIT P/N:	WITH NO AUX. VALVE PORTS	WITH 2 AUX. VALVE PORTS
SPRING CTR	5031	B10-100	5002-A1	5002-A269
3 POS. DETENTED	5031	B11-100	5002-A2	5002-A511
SPRING CTR FLT IN NEUTRAL (MOTOR)	5051	B10-100	5002-A10	5002-A522
3 POS DET FLT IN NEUTRAL (MOTOR)	5051	B11-100	5002-A11	5002-A654
3 POS. - 3 WAY				
SPRING CTR (SINGLE ACTING)	5030	B10-100	5002-A4	5002-A655*
** 4 POS. - 4 WAY			* ONLY ONE AUX. PORT ("A" SIDE)	
SPRING CTR DETENTED FLOAT	5032	B11-105	5002-A8	5002-A465

STANDARD SPRING CENTERING FORCES (SPRING P/N: 5014) = 37 LBS.

USED IN SECTION ② OF THE VALVE
ASSEMBLY SPECIFICATION SHEET

PARALLEL CIRCUIT MANUALLY OPERATED LOCK-OUT SPOOL SECTION ASSEMBLY

(PILOT OPERATED CHECK SECTION)

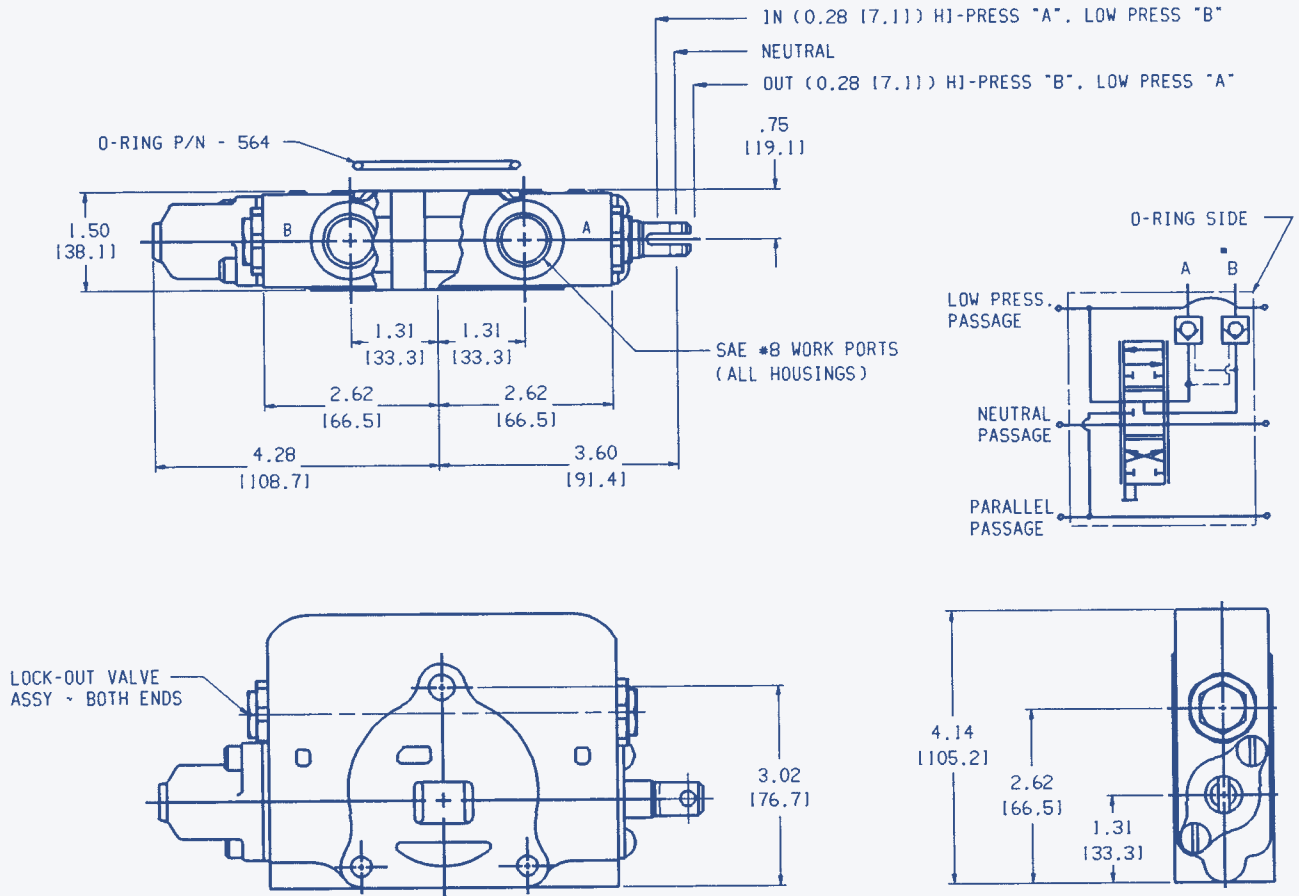

3 POS. - 4 WAY		SPOOL AND END MECHANISM IN ← → OUT	SPOOL P/N:	END MECHANISM KIT P/N:	SPOOL SECTION ASSY. PART NUMBER
	SPRING CTR	50963-1	B10-100	5002-YA2	

STANDARD SPRING CENTERING FORCES (SPRING P/N: 5014) = 37 LBS.

USED IN SECTION ② OF THE VALVE
ASSEMBLY SPECIFICATION SHEET

PARALLEL CIRCUIT HYDRAULIC REMOTE (OIL PILOT OPERATED) SPOOL SECTION ASSEMBLIES

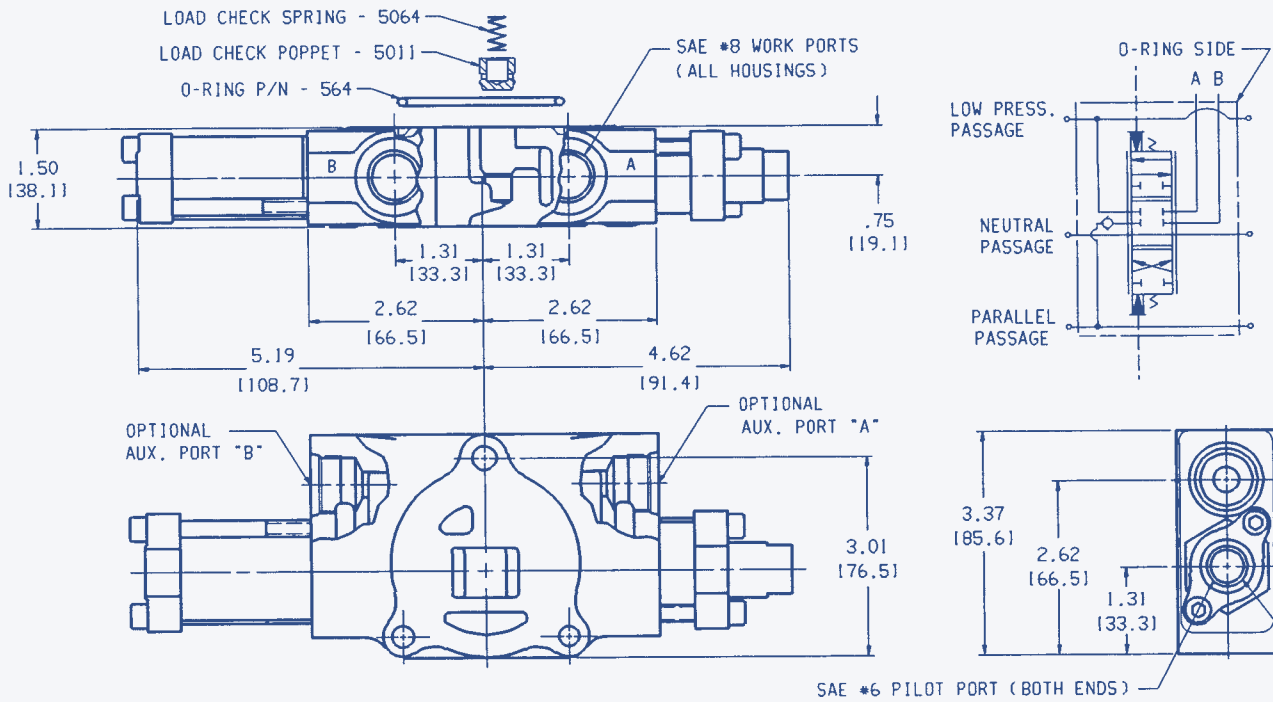

WHEN PILOT PRESSURE IS APPLIED TO THIS PILOT PORT SECTION SENSES HI-PRESS. "A", LOW PRESS. "B". WHEN PILOT PRESSURE IS APPLIED TO OPPOSITE PILOT PORT SECTION SENSES HI-PRESS. "B", LOW PRESS. "A". WHEN NO PILOT PRESSURE IS APPLIED SECTION SENSES NEUTRAL.

3 POS. - 4 WAY		SPOOL SECTION ASSY. PART NUMBERS		
SPOOL AND END MECHANISM IN → OUT	SPPOOL P/N:	END MECHANISM KIT P/N:	WITH NO AUX. VALVE PORTS	WITH 2 AUX. VALVE PORTS
SPRING CTR	5031	B12-108	5002-A831	5002-A832
SPRING CTR MOTOR	5051	B12-108	5002-A833	5002-A834

APPROXIMATE PILOT PRESSURE VS SPOOL TRAVEL:
 20 PSI -- SPOOL STARTS TO SHIFT
 80 PSI -- FLOW BEGINS AT WORK PORT
 360 PSI -- FULL SPOOL SHIFT, FULL WORK PORT FLOW
 1000 PSI -- MAX.

USE WITH HUSCO MANUAL HYDRAULIC CONTROLLERS:
 STD. SECTIONAL TYPE: P/N 7470-A15 (1-SPOOL OPERATION)
 STD. JOYSTICK TYPE: P/N 7480-19 (2-SPOOL OPERATION)

USED IN SECTION ② OF THE VALVE ASSEMBLY SPECIFICATION SHEET

PARALLEL CIRCUIT ELECTRIC SPOOL SECTION ASSEMBLIES

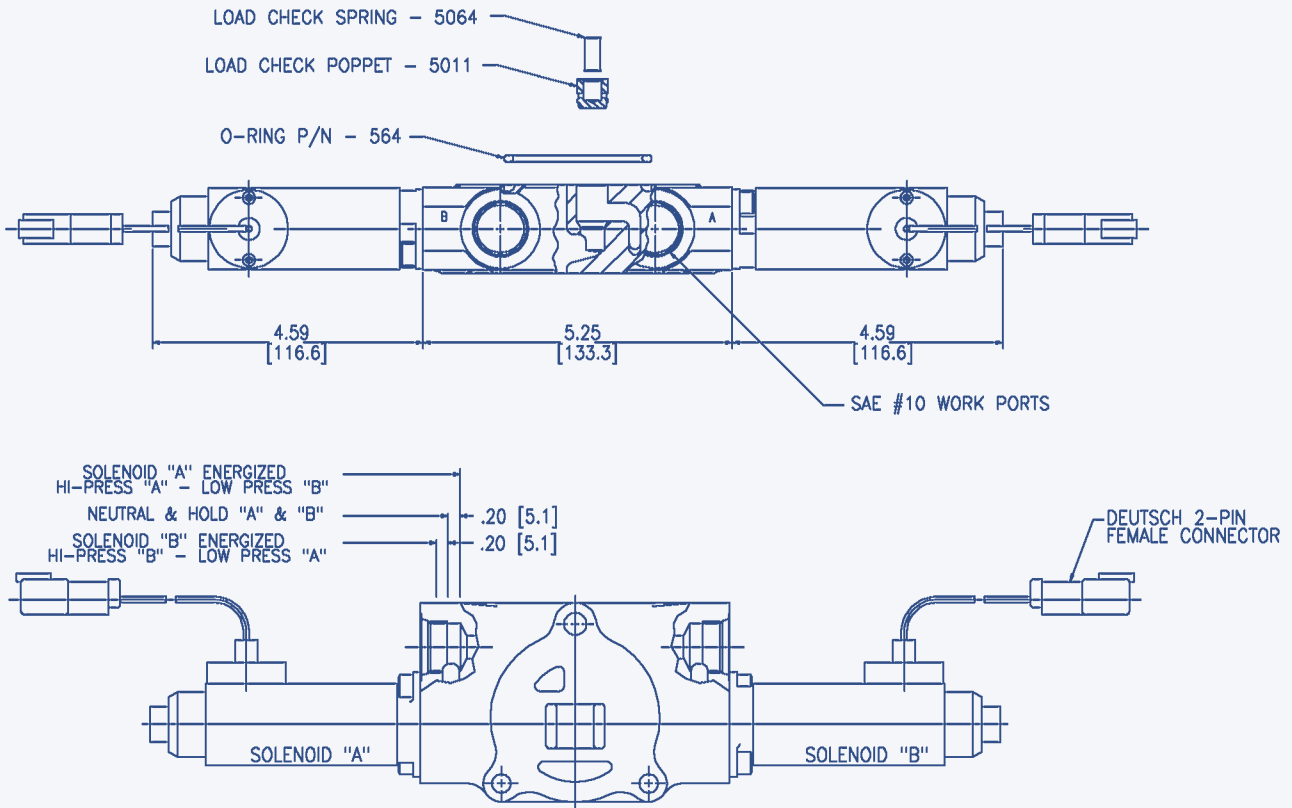

3 POS.-4 WAY		SPOOL SECTION ASSY. PART NUMBERS			
SPOOL AND END MECHANISM IN → OUT	SPOOL P/N:	SOLENOID P/N:	WITH NO AUX. VALVE PORTS	WITH 2 AUX. VALVE PORTS	
SPRING CTR	52310	54077-5	5002-A1156	5002-A963	

SOLENOID SPECIFICATIONS:
 VOLTAGE: 12 VDC NOMINAL
 CURRENT: 4.6 AMPS
 POWER: 54 WATTS
 FORCE: 40 N
 STROKE: 0.20" [5.1 mm]
 TYPE: ON/OFF
 CONTINUOUSLY RATED

USED IN SECTION ② OF THE VALVE
 ASSEMBLY SPECIFICATION SHEET

CONVENTIONAL CIRCUIT MANUALLY OPERATED SPOOL SECTION ASSEMBLIES (TANDEM)

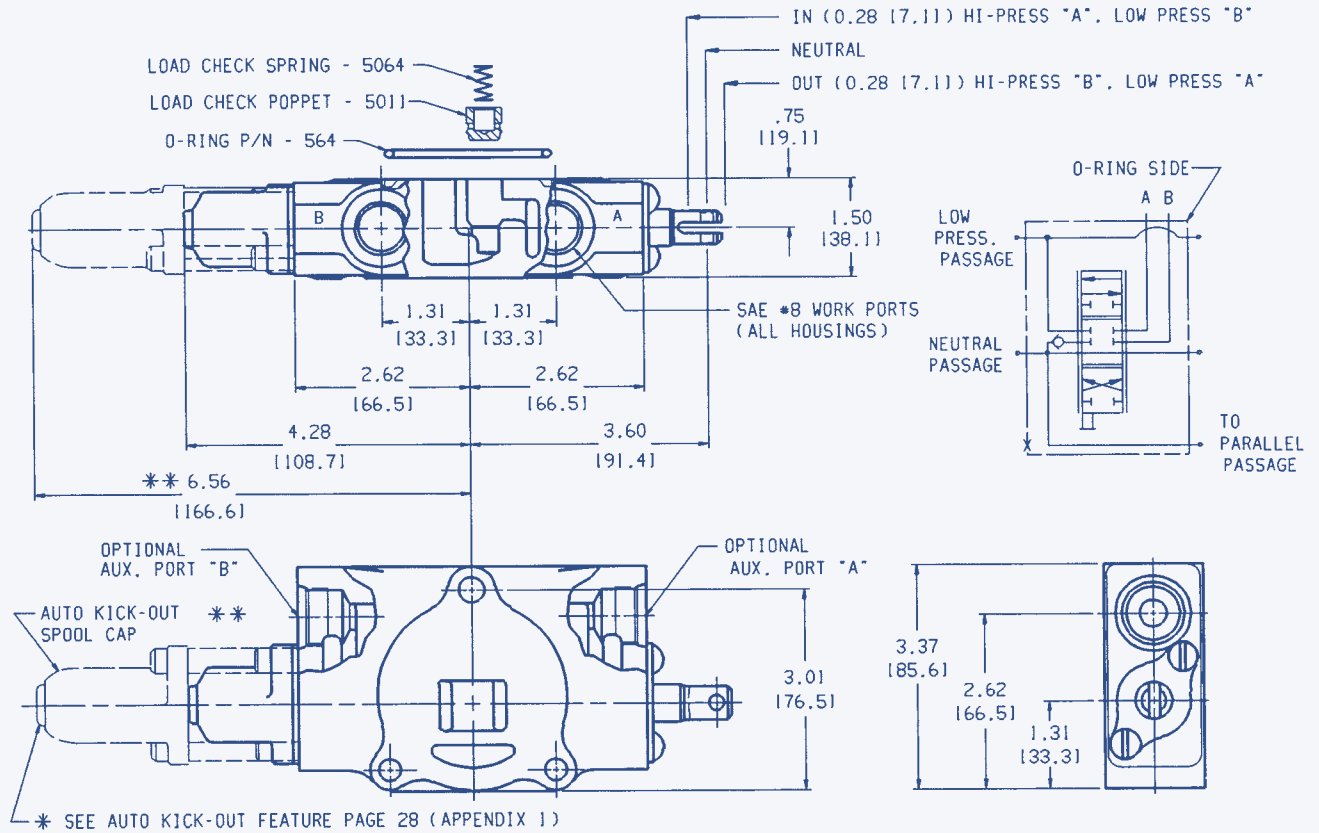

3 POS. - 4 WAY			SPOOL SECTION ASSY. PART NUMBERS	
SPOOL AND END MECHANISM IN → OUT	SPOOL P/N:	END MECHANISM KIT P/N:	WITH NO AUX. VALVE PORTS	WITH 2 AUX. VALVE PORTS
SPRING CTR	5031	B10-100	5002-B3	5002-B135
** 3 POS. - 4 WAY (AUTO KICK-OUT)				
SPRING CTR DETENT IN & OUT (AUTO KICK-OUT)	N/A	N/A	5002-B141	5002-B142

STANDARD SPRING CENTERING FORCES (SPRING P/N: 5014) • 37 LBS.

* REMOVE CAP FOR AUTO KICK-OUT ADJUSTMENTS. USE FLAT HEAD SCREWDRIVER FOR ADJUSTING. (SEE Pg. 28)

FACTORY SET AT 2000 PSI.

SETTING RANGE: 1000 - 2500 PSI

USED IN SECTION ② OF THE VALVE
ASSEMBLY SPECIFICATION SHEET

SERIES CIRCUIT MANUALLY OPERATED SPOOL SECTION ASSEMBLIES

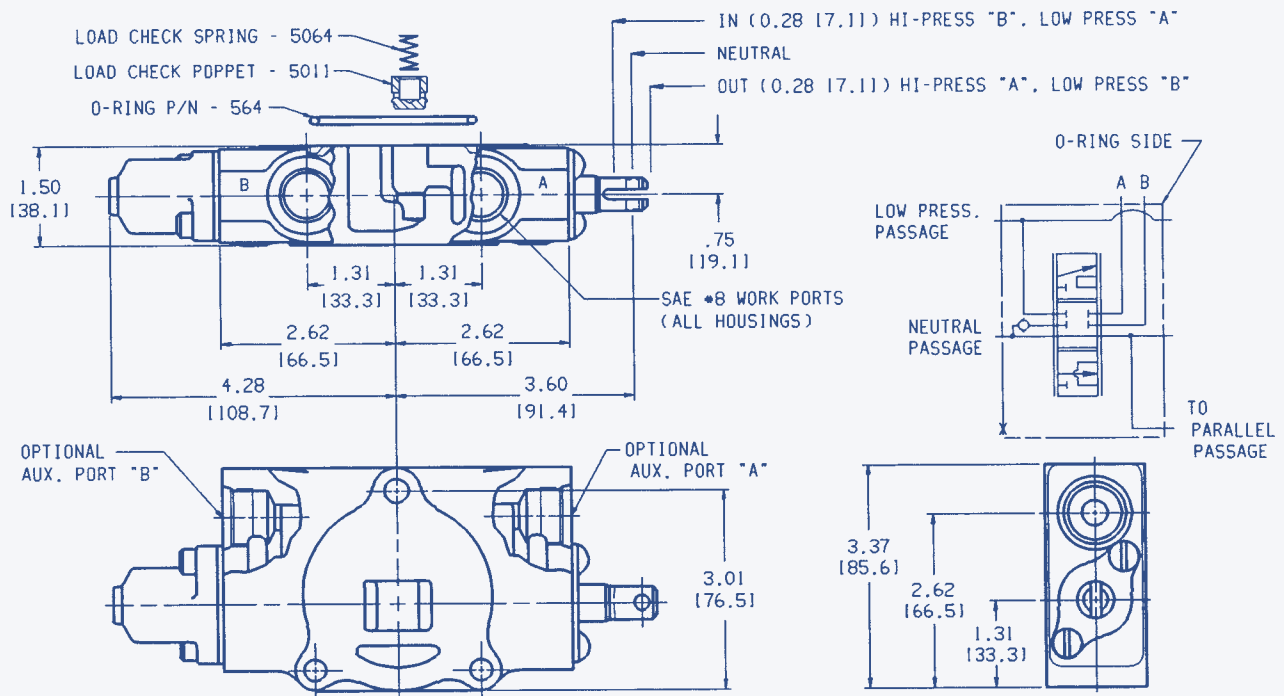

FULL SECTION VIEW OF P/N: 5002E36

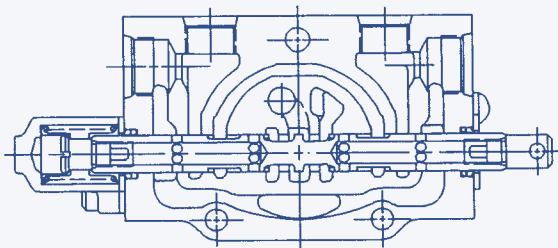

SERIES CIRCUITRY IS ACCOMPLISHED BY USING A HOLLOW SPOOL

NOTE: BECAUSE THE WORK PORT TO TANK FLOW PATH IS THROUGH A HOLLOW SPOOL, THE WORK PORT TO TANK PRESSURE DROP ON SERIES SECTION ASSEMBLIES INCREASES APPROXIMATELY 300% OVER THE AMOUNT LISTED ON THE GRAPH ON PAGE 5. ALL OTHER PRESSURE DROPS REMAIN THE SAME. THE SERIES SPOOL SECTION ASSEMBLY IS THE ONLY SECTION THAT IS SYMMETRICAL AND CAN BE CONVERTED FROM R. H. (STD) TO L. H. ASSEMBLY.

3 POS. - 4 WAY			SPOOL SECTION ASSY. PART NUMBERS	
SPOOL AND END MECHANISM IN → OUT	SPOOL P/N:	END MECHANISM KIT P/N:	WITH NO AUX. VALVE PORTS	WITH 2 AUX. VALVE PORTS
SPRING CTR	52261	B10-103	5002-E31	5002-E36

STANDARD CENTERING SPRING FORCES (SPRING P/N: 5014) - 37 LBS.

USED IN SECTION ② OF THE VALVE ASSEMBLY SPECIFICATION SHEET

OUTLET SECTION ASSEMBLIES

END OUTLET/TURNAROUND (OPEN-CENTER SYSTEM)

PORT SIZE	OUTLET SECTION PART NUMBER
NONE	5003-A1 *
SAE 12	5003-A3

* REQUIRES UPSTREAM OUTLET PORT SOMEWHERE ELSE IN VALVE STACK

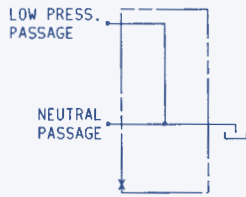

WEIGHT : APPROX. 2.0 LBS. 10.91 kg

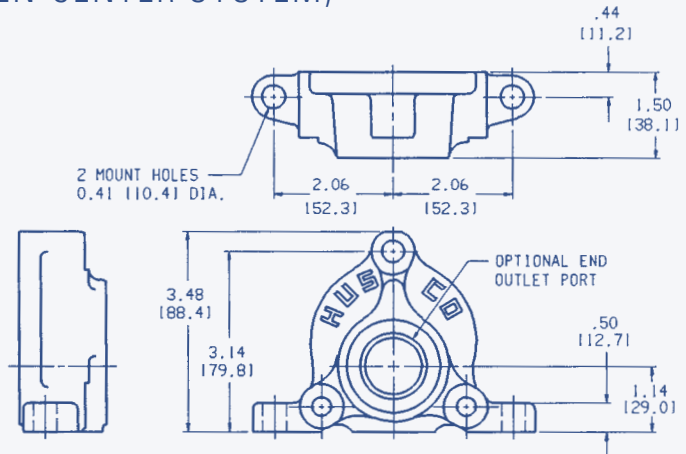

OUTLET SECTION W/TOP OUTLET PORT (OPEN-CENTER SYSTEM)

PORT SIZE	OUTLET SECTION PART NUMBER
SAE 10	5003-A9

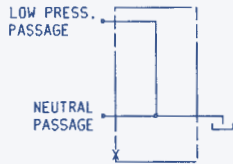

WEIGHT : APPROX. 2.6 LBS. 11.21 kg

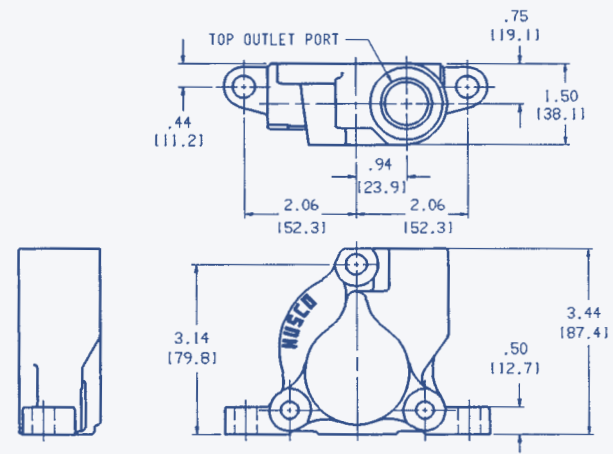

POWER BEYOND/CLOSED-CENTER

PORT SIZE	OUTLET SECTION PART NUMBER
SAE 10	5003-E2
SAE 12	5003-E5

REQUIRES UPSTREAM OUTLET PORT IN VALVE STACK FOR POWER BEYOND OPERATION.

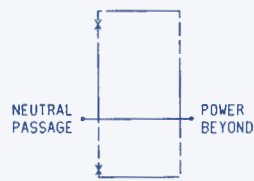

WEIGHT : APPROX. 2.4 LBS. 11.11 kg

TO CREATE A CLOSED CENTER CIRCUIT, PLUG POWER BEYOND PORT.

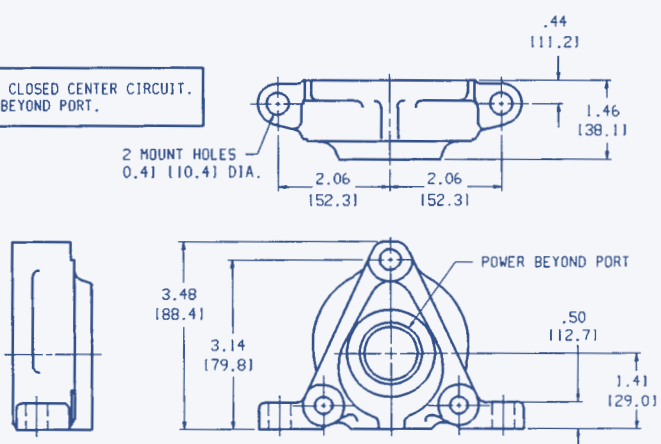

UNIVERSAL OUTLET/POWER BEYOND OPTION SECTION ASSEMBLIES

AUXILIARY VALVE PORT CIRCUIT OPTIONS (ALL SOLD SEPARATELY)

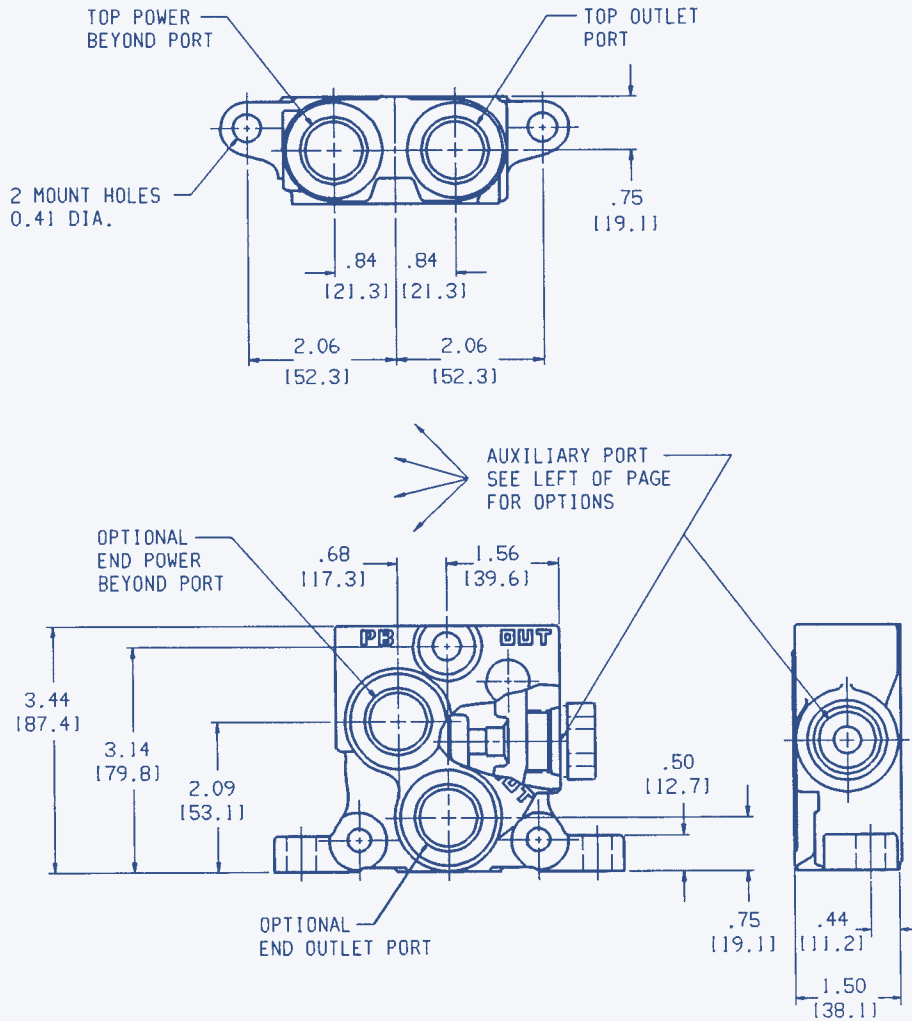
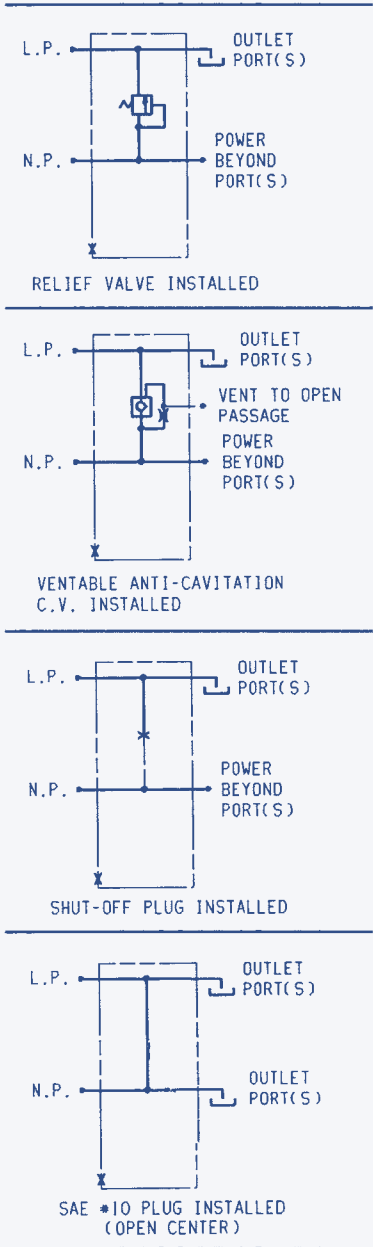

PORT SIZES				OUTLET SECTION PART NUMBERS
OUTLET		POWER BEYOND		
TOP	END	TOP	END	
SAE 10	NONE	SAE 10	NONE	5003-A67
SAE 10	SAE 12	SAE 10	SAE 12	5003-A68

TO CREATE A CLOSED CENTER CIRCUIT, PLUG POWER BEYOND PORT(S) AND INSTALL SHUT-OFF PLUG IN AUXILIARY PORT.

USED IN SECTION ③ OF THE VALVE ASSEMBLY SPECIFICATION SHEET

SEE CUT-AWAY PHOTO Pg. 19

CUTAWAY VIEW AND DOWNSTREAM VIEW (O-RING FACE) OF INLET END SECTION ASSEMBLY P/N 5001-A88

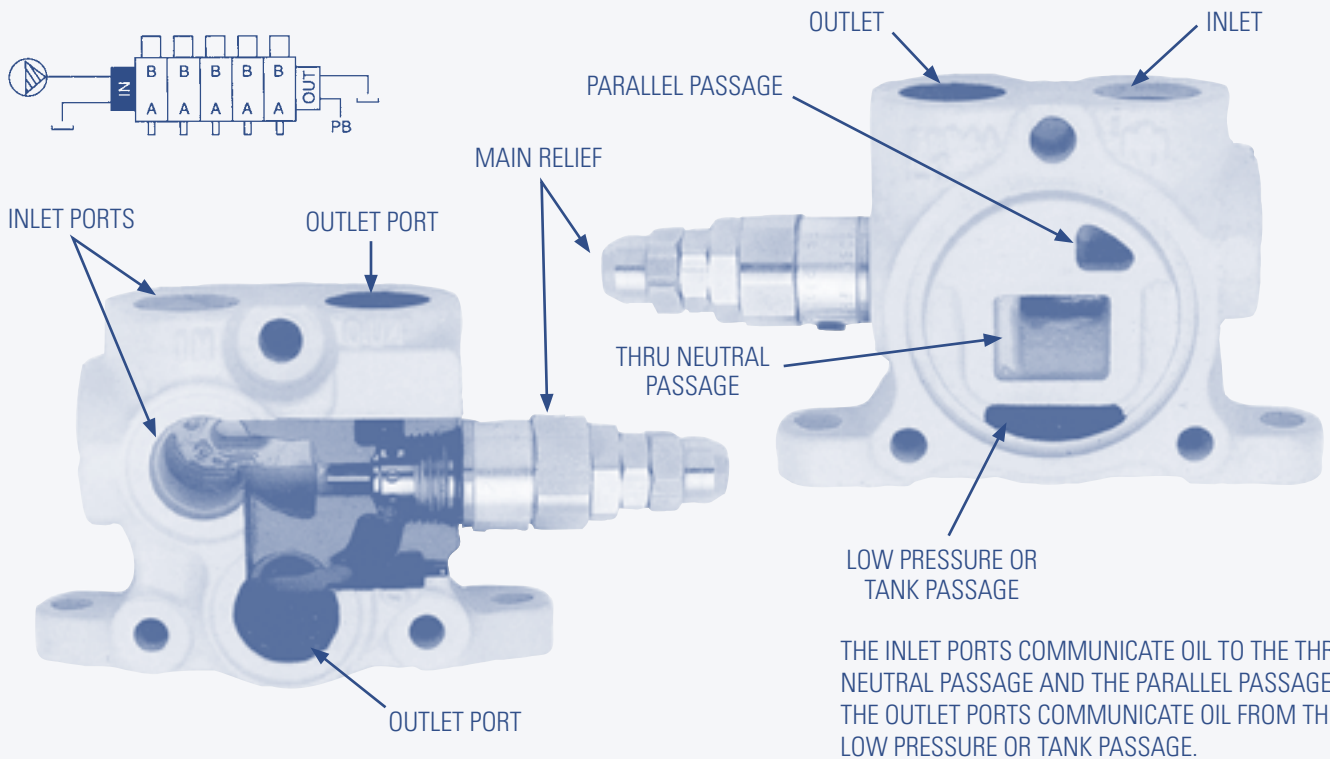

CUTAWAY VIEW AND UPSTREAM VIEW (NON-O-RING FACE) OF OUTLET END SECTION ASSEMBLY P/N 5003-A68

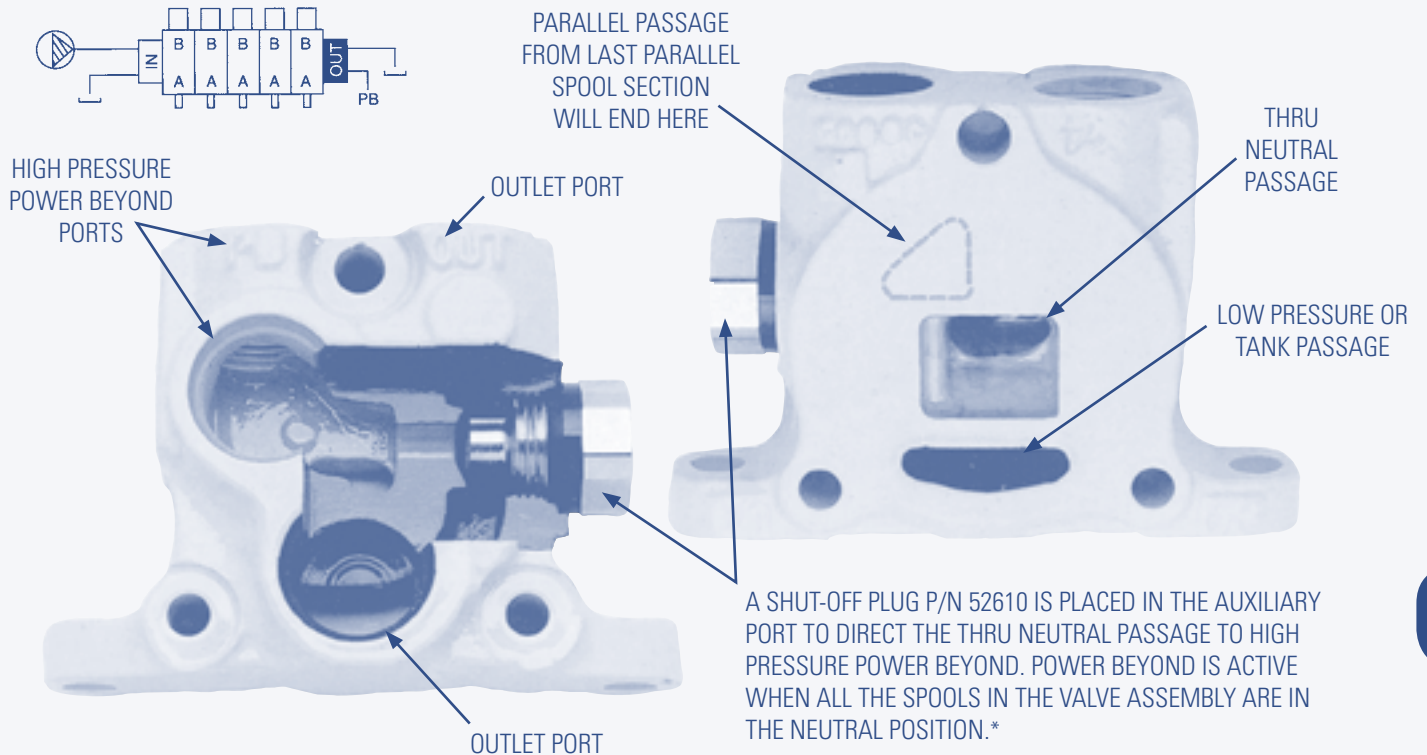

*Exception: series circuit valve section assemblies return discharged oil to neutral passage. (See page 18 for other circuit options)

MODEL 5060 PILOT OPERATED RELIEF VALVE WITH ANTI-VOID

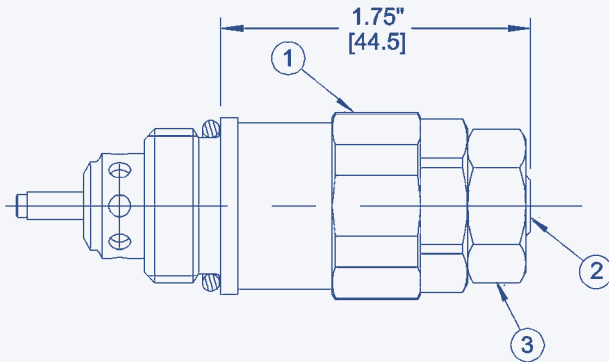

INSTALLATION AND ADJUSTMENT PROCEDURE

TORQUE MAIN BODY #1 INTO VALVE HOUSING USING 30 - 36 FT. LBS.

TO ADJUST PRESSURE SETTING, LOOSEN JAM NUT #3. TURN ADJUST SCREW #2 TO DESIRED SETTING. RE-TIGHTEN JAM NUT USING 6 - 8 FT. LBS.

RELIEF VALVE ASSY. P/N	PRESSURE SETTING RANGE:	SPRING & SEAL KIT P/N:	SPRING P/N:	FACTORY SETTING AT 5 GPM	ADJUSTMENT VALUES PER 1/4 TURN
5060-B	100 - 1500 PSI	51790-1	5424	1000 PSI	200 PSI
5060-P	1500 - 3500 PSI	51790-3	53979	2000 PSI	550 PSI

5060-P RELIEF VALVE PERFORMANCE DATA

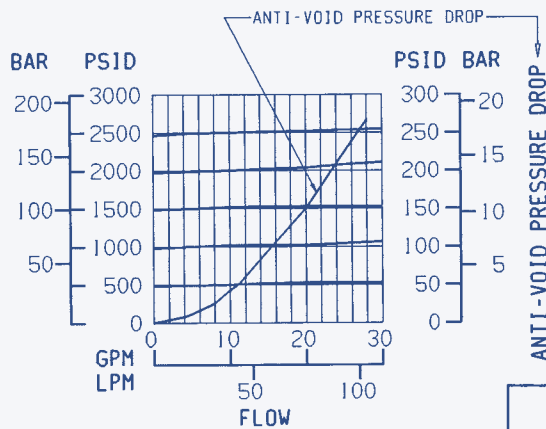

ABOUT THE 5060....

THE 5060 RELIEF VALVE IS THE WORKHORSE OF THE MODEL 5000 CONTROL VALVE LINE. THE 5060 IS USED AS A MAIN, CYLINDER PORT OR POWER BEYOND PRESSURE RELIEF VALVE. ITS HIGH FLOW PERFORMANCE CHARACTERISTICS AND ANTI-VOID CAPABILITIES MAKE IT THE UNIVERSAL CHOICE. THERE ARE OVER 2 MILLION 5060 RELIEFS IN OPERATION TODAY.

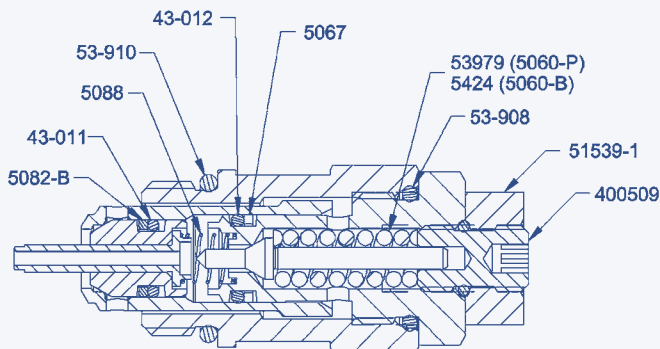

FOR KIT 51790-1 SPRING P/N 5424 REPLACES SPRING P/N 53979

SEAL & SPRING KIT 51790-3

PART NO.	DESCRIPTION	QTY.
400509	ADJUST SCREW ASSY.	1
43-011	O-RING	1
43-012	O-RING	1
5067	BACK-UP RING	1
5082-B	BACK-UP RING	1
5088	SPRING	1
51539-1	JAM NUT	1
53-908	O-RING	1
53-910	O-RING	1
53979	SPRING	1
A1003-2	INSTRUCTION SHEET	1

MODEL 52710 DIRECT ACTING RELIEF VALVE

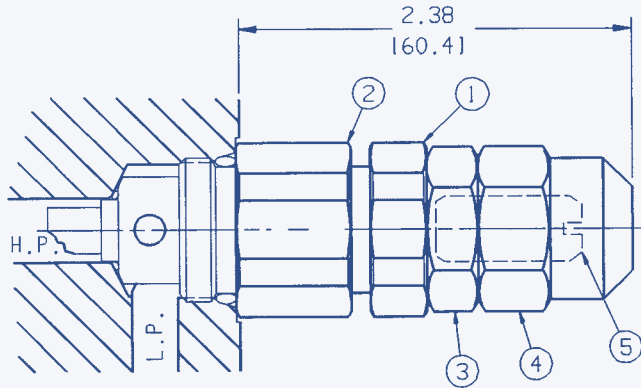

INSTALLATION AND ADJUSTMENT PROCEDURE

TORQUE MAIN BODY #1 INTO VALVE HOUSING THEN TORQUE LOCK NUT #2 USING 29.5 - 36.5 FT.-LBS. ON BOTH.

TO ADJUST PRESSURE SETTING, REMOVE ACORN NUT #4 AND LOOSEN JAM NUT #3. TURN ADJUST SCREW #5 TO DESIRED SETTING. RE-TIGHTEN JAM NUT AND ACORN NUT USING 9 - 11 FT.-LBS.

RELIEF VALVE ASSY. P/N	PRESSURE SETTING RANGE:	SPRING & SEAL KIT P/N:	SPRING P/N:	FACTORY SETTING AT 5.0 GPM	ADJUSTMENT VALUES PER 1/4 TURN
52710-B	500-1500 PSI	52727-1	52708	1000 PSI	175 PSI
52710-C	1500-3500 PSI	52727-2	52704	2000 PSI	250 PSI

52710 RELIEF VALVE PERFORMANCE DATA

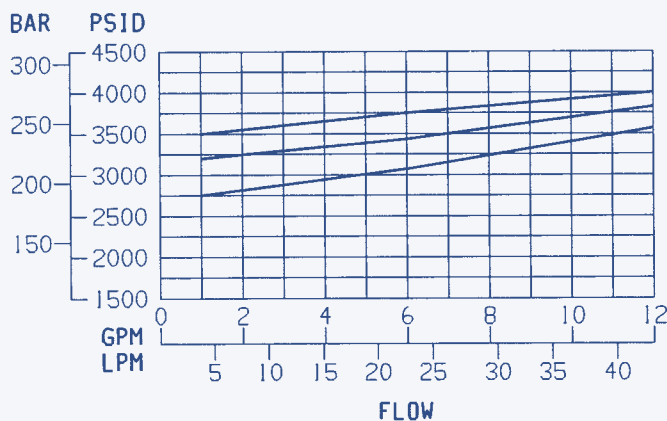

ABOUT THE 52710....

THE 52710 SERIES RELIEF IS A LOW COST, LOW FLOW, DIRECT ACTING RELIEF CARTRIDGE THAT FITS IN ALL THE AUXILIARY PORTS LISTED IN THIS CATALOG. IT IS USED EXTENSIVELY AS A CYLINDER PORT RELIEF WHEN A FULL FLOW RELIEF IS NOT NECESSARY. THIS RELIEF IS COMMONLY USED FOR ELIMINATING THE EFFECTS OF LOW FLOW PEAK PRESSURE SPIKES.

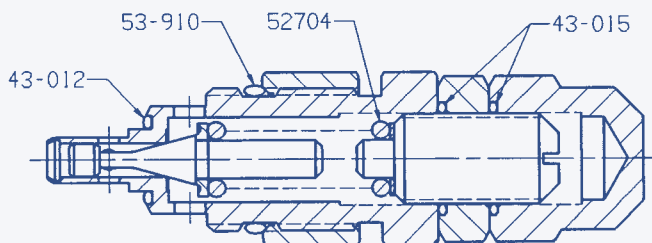

SPRING & SEAL KIT 52727-2 *

PART NO.	DESCRIPTION	QTY.
43-012	O-RING	1
43-015	O-RING	2
52704	SPRING	1
53-910	O-RING	1

* FOR KIT 52727-1 SPRING P/N 52708 REPLACES SPRING P/N 52704

ANTI-CAVITATION CHECK VALVE

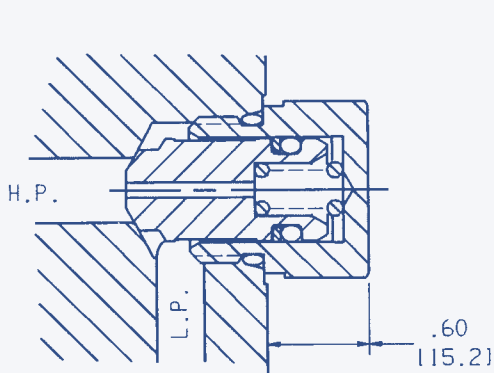

THE ANTI-CAVITATION CHECK VALVE OPENS WHEN L.P. PASSAGE PRESSURE EXCEEDS THE H.P. PASSAGE PRESSURE.

P/N:	TORQUE
5475	29.5 - 36.5 FT.-LBS.

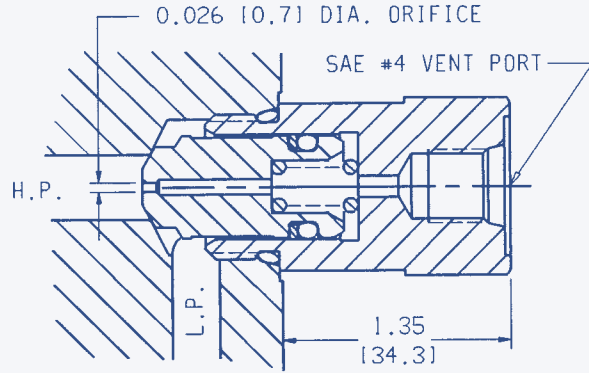

THE VENTABLE ANTI-CAVITATION CHECK VALVE OPENS WHEN THE L.P. PASSAGE PRESSURE EXCEEDS THE H.P. PASSAGE PRESSURE OR WHEN THE VENT PORT IS OPENED TO TANK.

P/N:	TORQUE
52540-1	29.5 - 36.5 FT.-LBS.

SHUT-OFF PLUG ASSEMBLY

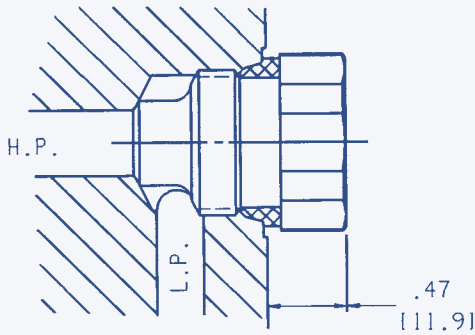

THE SHUT-OFF PLUG IS USED TO SHUT-OFF THE L.P. PASSAGE FROM THE H.P. PASSAGE IN ALL THE AUX. VALVE PORTS. IT IS USED TO PLUG THE AUX. VALVE PORT WHEN AN AUX. VALVE IS NOT REQUIRED. THE SHUT-OFF PLUG IS ALSO USED IN THE OUTLET SECTION TO ACTIVATE THE POWER BEYOND PORT(S).

P/N:	TORQUE
52610	29.5 - 36.5 FT.-LBS.

MODEL 5000 TIE ROD KITS

P/N:	NUMBER OF SECTIONS
6131-1	1
6131-2	2
6131-3	3
6131-4	4
6131-5	5
6131-6	6
6131-7	7
6131-8	8
6131-9	9
6131-10	10
6131-11	11

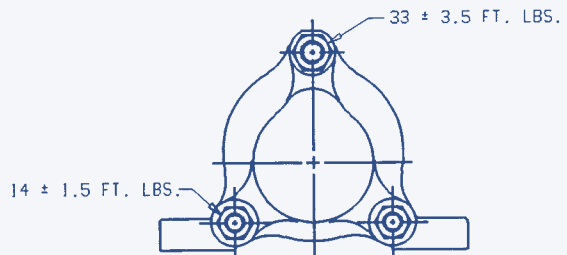

TIE ROD HOLE PATTERN
TORQUE - ANY QTY. OF SECTIONS

STANDARD SAE PLUG AND O-RING ASSEMBLY

DESCRIPTION	P/N:	TORQUE
#8 SAE	11150	29.5-36.5 FT.-LBS.
#10 SAE	11180	43-53 FT.-LBS.
#12 SAE	11210	66-82 FT.-LBS.

FIXED POSITION LEVER W/BOOT

NOTE: SEE APPENDIX 3 FOR PARTS LISTING

LEVER TRAVEL TYPICAL FOR EACH ASSY

NOTE: LEVERS MAY BE MOUNTED 180° FROM THE POSITIONS SHOWN

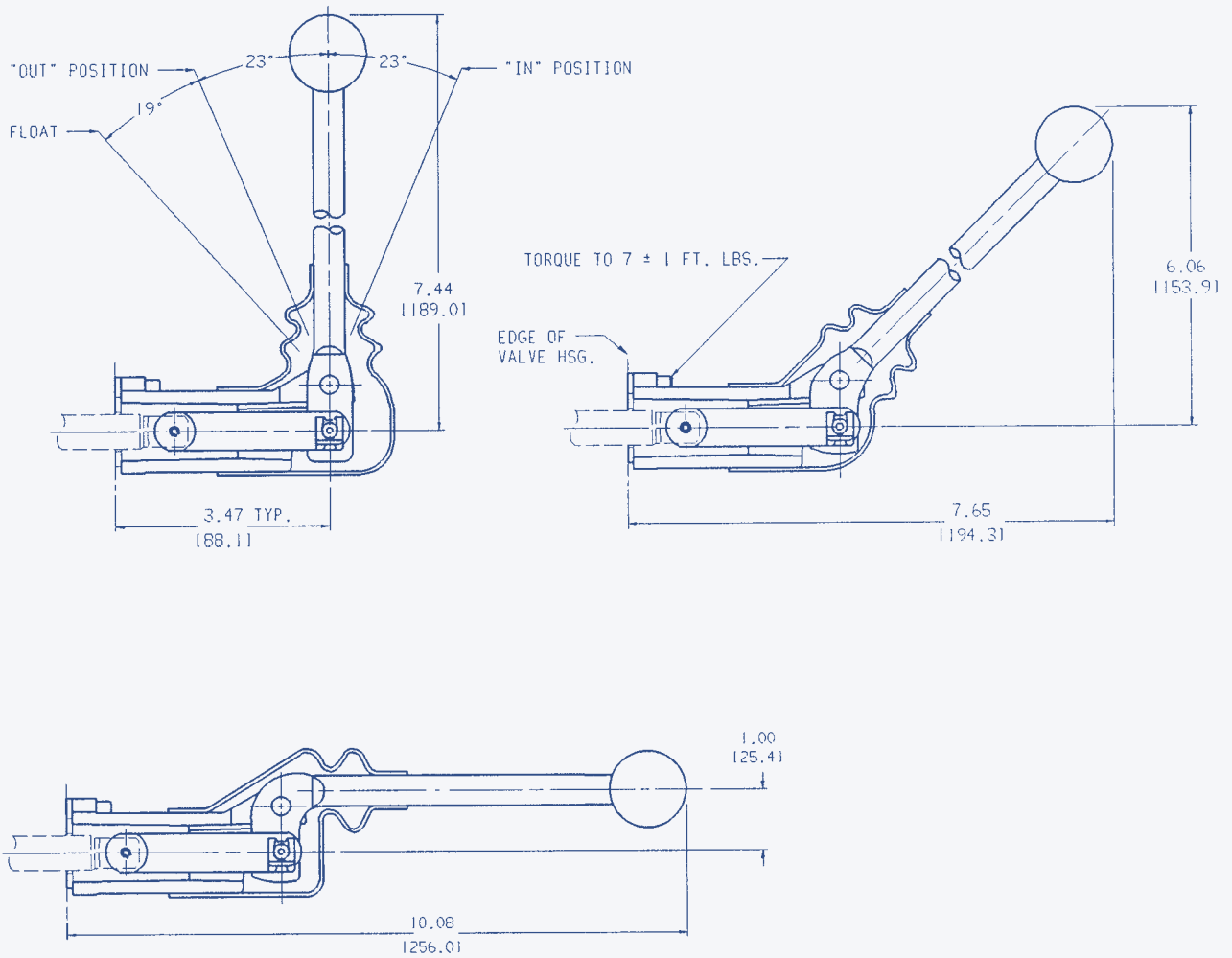

FIXED POSITION	P/N:
VERTICAL	52250-1
HORIZONTAL	52250-12
45°	52250-14

HEAVY DUTY MECHANICAL JOYSTICK
FOR SIMULTANEOUS CONTROL OF TWO SPOOL SECTIONS

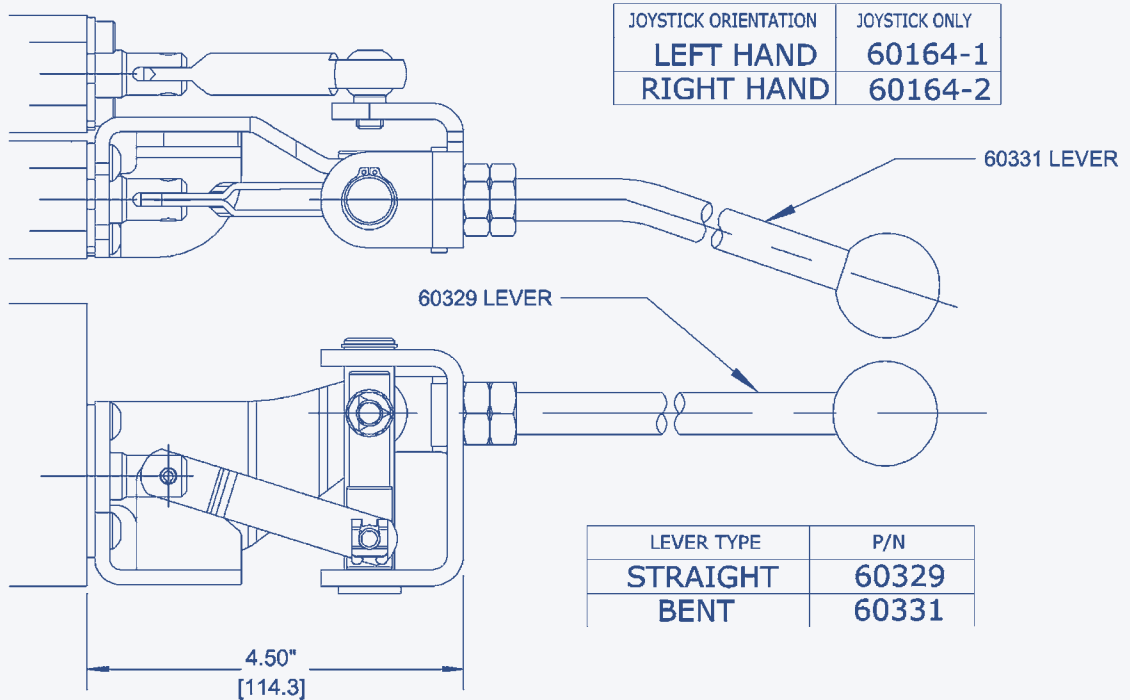

INFINITE POSITION LEVER

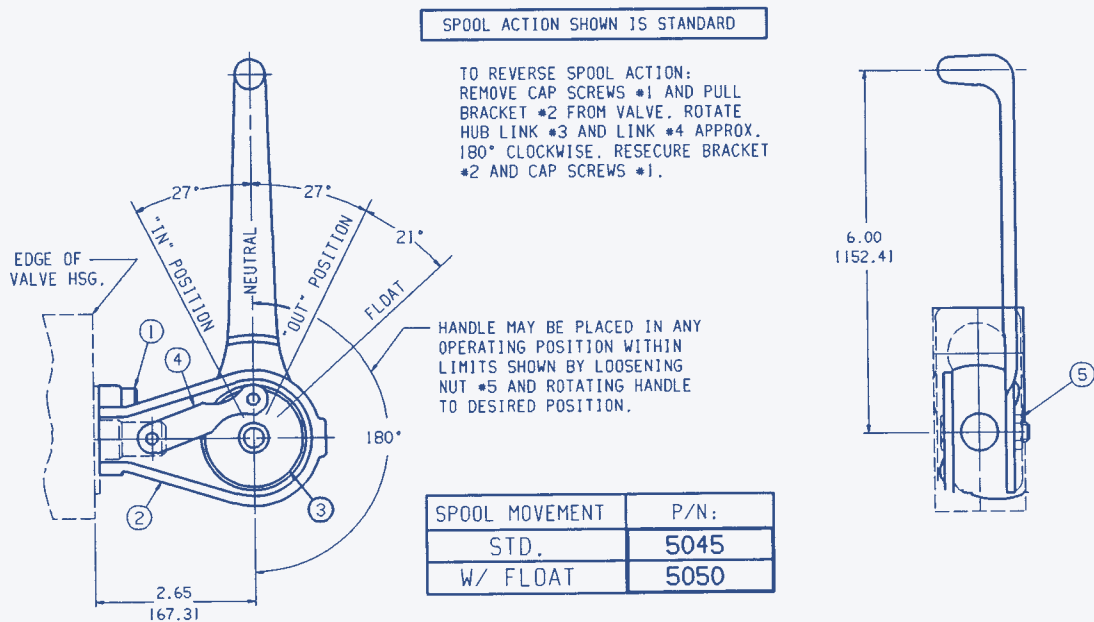

FOR PARALLEL AND CONVENTIONAL CIRCUIT SECTIONS

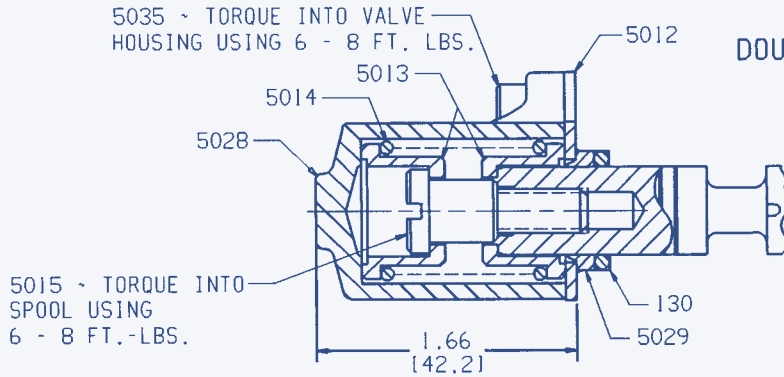

3 POSITION, 4 WAY
DOUBLE ACTING SPRING CENTERED

KIT #B10-100

PART NO.	DESCRIPTION	QTY.
130	O-RING	1
5012	SEALPLATE	1
5013	SPRING SEAT	2
5014	SPRING	1
5015	SPOOL END	1
5028	CAP	1
5029	WIPER	1
5035	CAP SCREW	2

FOR SERIES CIRCUIT SECTIONS USE: KIT #B10-103 (P/N 51983 AND P/N 4623 REPLACE P/N 5015)

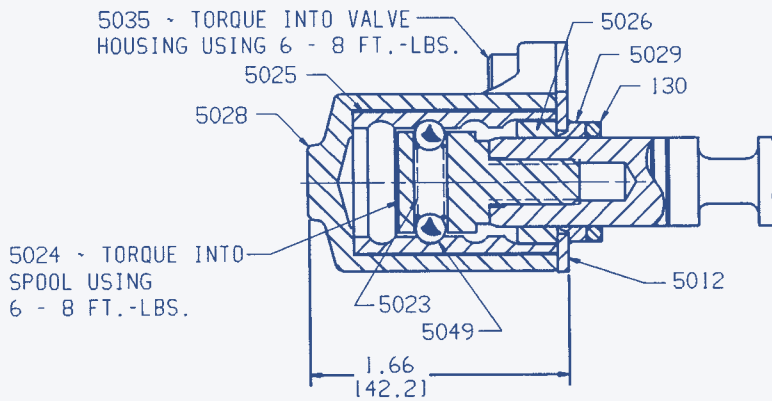

3 POSITION, 4 WAY
DOUBLE ACTING DETENT

KIT #B11-100

PART NO.	DESCRIPTION	QTY.
130	O-RING	1
5012	SEALPLATE	1
5023	SPRING	1
5024	DET. PIN	1
5025	DET. SLEEVE	1
5026	SPACER	1
5028	CAP	1
5029	WIPER	1
5035	CAP SCREW	2
5049	BALL	2

FOR SERIES CIRCUIT SECTIONS USE: KIT #B11-119 (P/N 52272 AND P/N 4623 REPLACE P/N 5024)

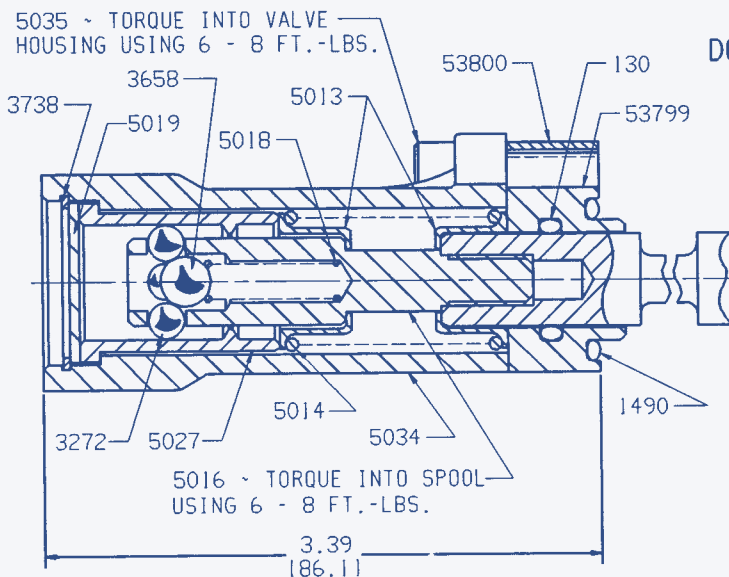

4 POSITION, 4 WAY
DOUBLE ACTING SPRING CENTERED
DETENT "IN" FLOAT

KIT #B11-105

(NOT FOR CONVERSION)

PART NO.	DESCRIPTION	QTY.
130	O-RING	1
1490	O-RING	1
3424	CAP SCREW	2
5013	SPRING SEAT	2
5014	SPRING	1
5018	SPRING	1
5019	SPACER	1
5021	DET. PIN	1
5027	DET. SLEEVE	1
5034	CAP	1
3272	BALL	4
3658	BALL	1
3738	RET. RING	1
53799	SPACER	2
53800	SPACER	1

HYDRAULIC REMOTE (OIL PILOT OPERATED)

KIT P/N: B12-108

PART NO.	DESCRIPTION	QTY.
41-019	O-RING	2
5141	O-RING	1
52193	SPRING	1
5243	CAP SCREW	2
52824	CAP SCREW	2
55032	CAP	1
55033	CAP	1
55034	SEALPLATE	2
55035	RETAINER	1
55036-1	SPOOL END	1
55037	SPRING SEAT	2
55047	BACK-UP RING	1

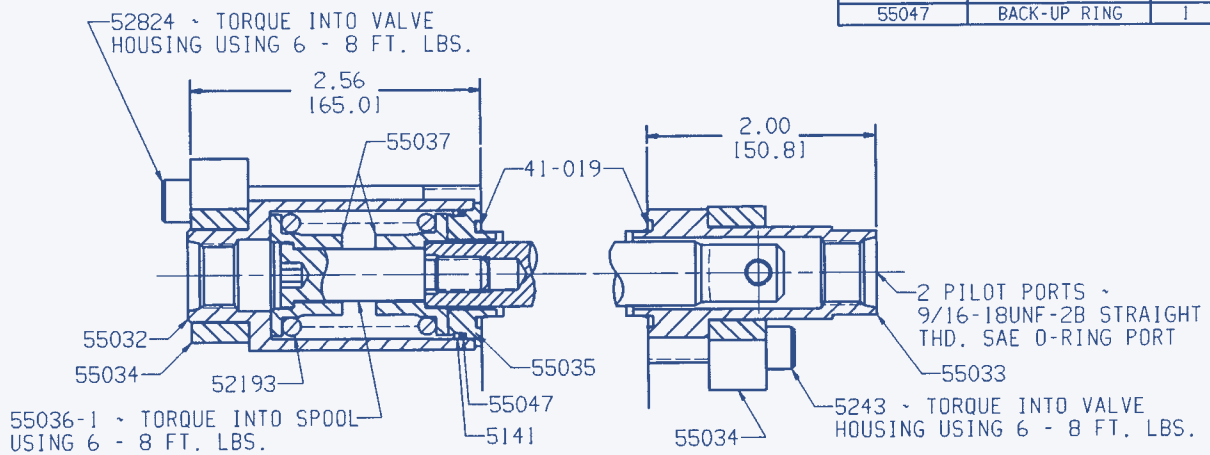

FOR SERIES CIRCUIT SECTIONS USE: KIT #B12-109
(P/N 55036 AND P/N 4623 REPLACE P/N 55036-1)

FOR PARALLEL AND CONVENTIONAL CIRCUIT SECTIONS

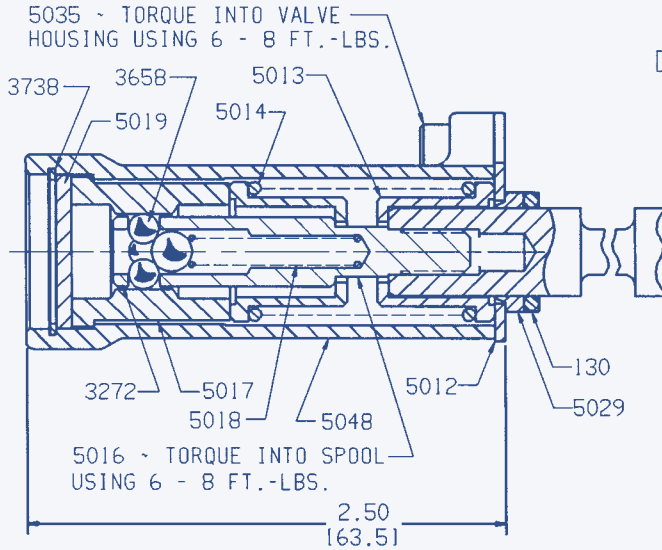

3 POSITION, 4 WAY
DOUBLE ACTING SPRING CENTERED
DETENT "IN" & "OUT"

KIT #B11-103

PART NO.	DESCRIPTION	QTY.
130	O-RING	1
5012	SEALPLATE	1
5013	SPRING SEAT	2
5014	SPRING	1
5016	DET. PIN	1
5017	DET. SLEEVE	1
5018	SPRING	1
5019	SPACER	1
5029	WIPER	1
5035	CAP SCREW	2
5048	CAP	1
3272	BALL	4
3658	BALL	1
3738	RET. RING	1

FOR SPR. CTR. DETENT "IN" ONLY USE: KIT #B11-101 (DET.SLEEVE P/N 5283 REPLACES P/N 5017)
FOR SPR. CTR. DETENT "OUT" ONLY USE: KIT #B11-102 (DET.SLEEVE P/N 5163 REPLACES P/N 5017)

FLOW RESTRICTORS

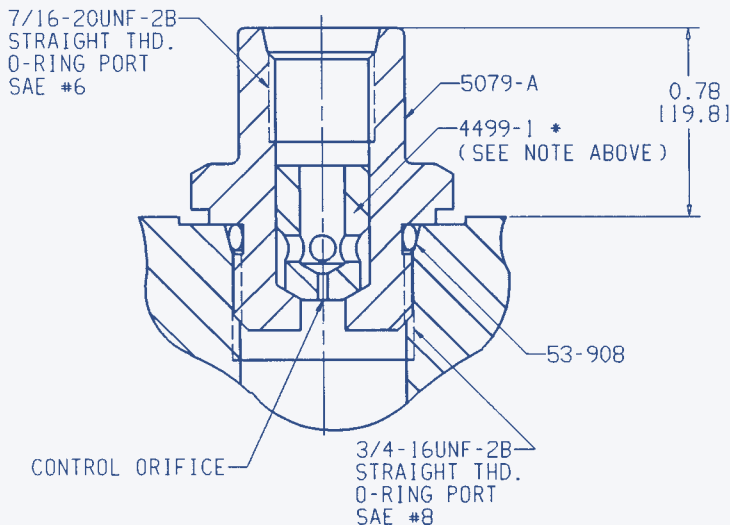
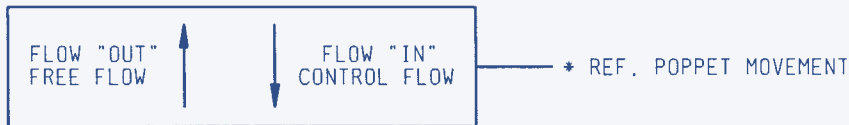

KIT P/N: 11901-2

PART NO.	DESCRIPTION	QTY.
5079-A	FITTING	1
4499-1	POPPET *	1
53-908	VITON O-RING	1

* POPPET HOLE SIZE .0430 IN. (1.1 MM)
CONSULT HUSCO FOR OTHER POPPET
SIZES THAT ARE AVAILABLE - OR
MACHINE ORIFICE TO DESIRED SIZE.

AUTOMATIC KICK-OUT FEATURE

The auto kick-out mechanism releases the spool to the center position at a pre-determined settable cylinder port pressure.

The illustration below identifies the working components of the auto kick-out mechanism. The auto kick-out mechanism is not available in kit conversion maintenance procedures.

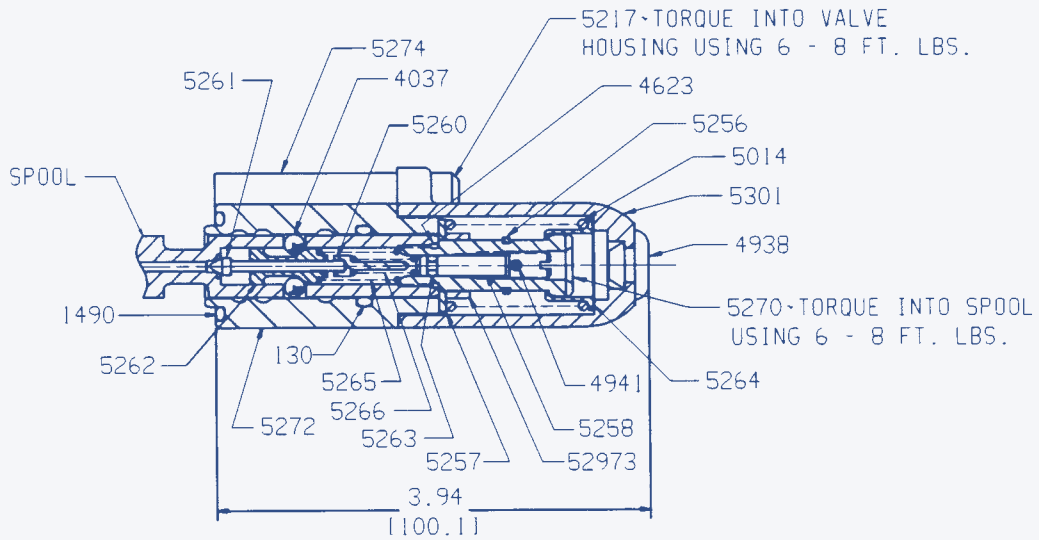

PART NO.	DESCRIPTION	QTY.
130	O-RING	1
1490	O-RING	1
4037	BALL	4
4623	O-RING	1
4938	PLUG	1
4941	LOCKING INSERT	1
5014	SPRING	1
5217	CAP SCREW	2
5256	RET. RING	1
5257	WASHER	1
5258	ADJUST SCREW	1
5260	SPRING GUIDE	1

PART NO.	DESCRIPTION	QTY.
5261	POPPET	1
5262	DET. CAM	1
5263	O-RING	1
5264	SPRING SEAT	1
5265	SPRING	1
5266	SPRING	1
5270	SPOOL END	1
5272	DET. SLEEVE	1
5274	SPACER	2
52973	SPACER	1
5301	CAP	1

AUTO KICK-OUT SETTING AND ADJUSTMENT

Adjustments to the auto kick-out valve section are made when integrated within a hydraulic circuit.

1. Install a pressure gauge and adjust the pressure.
2. With the hydraulic system off, shift auto kick-out valve section to a detented position.
3. Activate the hydraulic system to allow pressure to build. Note the pressure reading at time of kick-out; this will determine its current setting. Standard factory setting, if not specified, is 2000 PSI.
4. To make a pressure adjustment, turn the adjustment screw clockwise until desired setting is achieved. Adjustment range is 1000-2600 PSI. Run a few cycles to assure setting consistency, replace rubber plug. Note: Final main relief setting must be at least 250 PSI higher than the highest auto kick-out setting in the system.

Caution: To avoid damaged or lost parts do not remove adjustment screw.

SPOOL END ORIENTATION

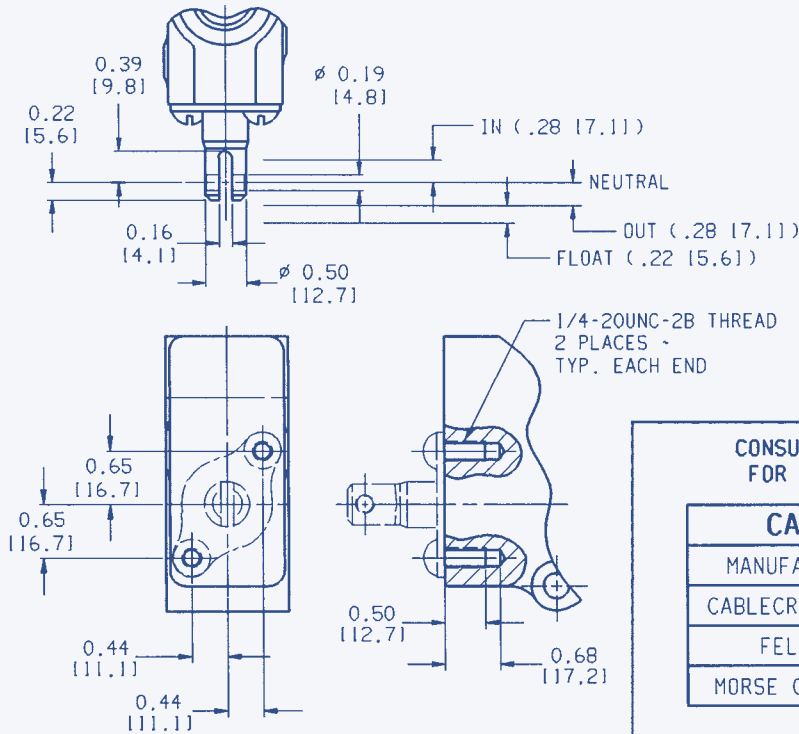

CONSULT CABLE MANUFACTURER FOR FURTHER INFORMATION

CABLE CONNECTORS	
MANUFACTURER	KIT P/N
CABLECRAFT INC.	*
FELSTED	59119
MORSE CONTROLS	306769

*KIT P/N 773-305-XX ~ (THREADED CABLE END AT CONTROLLER)

*KIT P/N 773-306-XXX ~ (CAM CABLE END AT CONTROLLER)

BASIC CASTING IDENTIFICATION

(NON-SERVICEABLE)

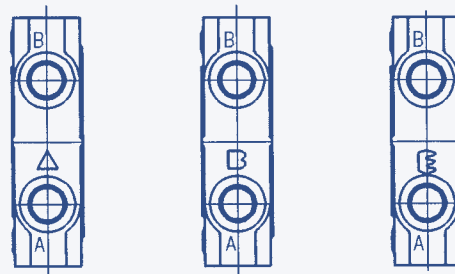

NOTE:
CASTING OPTIONS SHOWN ARE REPRESENTED IN THIS CATALOG.
CONTACT HUSCO FOR OTHER AVAILABLE OPTIONS.

SECTION ASSY. BASE No. (REF. ONLY)	5002A	5002B	5002E
CASTING BASE No. (REF. ONLY)	5005A	5005B	5005E
IRON TYPE	GREY	GREY	GREY
CIRCUIT	PARALLEL R.H.	CONVENTIONAL R.H.	SERIES R.H.

LEVER ASSEMBLIES – PARTS LISTING

FIXED POSITION LEVER W/ BOOT

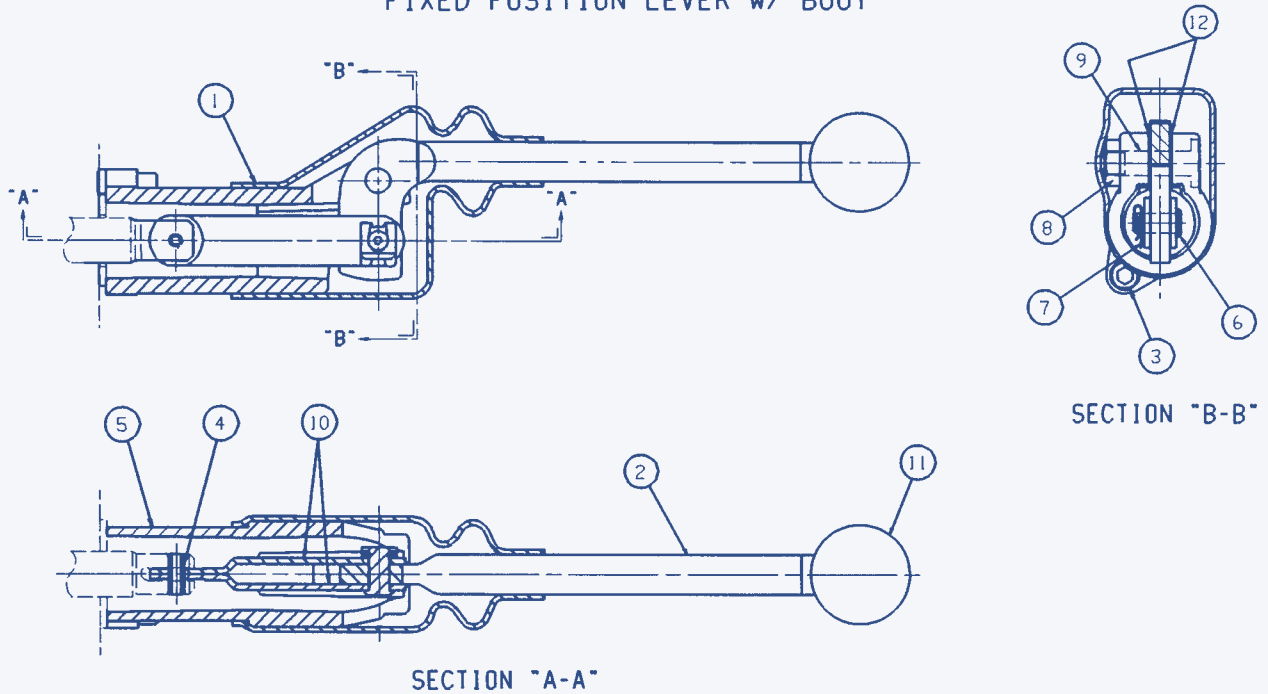

REF.: 52250-12 HANDLE ASSY. SHOWN

ITEM	DESCRIPTION	HANDLE ASSEMBLY P/N REFERENCE		
		VERTICAL	HORIZONTAL	45°
		52250-1	52250-12	52250-14
1	BOOT	51662	52348	51662
2	HANDLE	52552	52987-3	52663
3	CAP SCREW	5035		
4	ROLL PIN	5349		
5	HANDLE BRACKET	52128-1		
6	PIN	52214		
7	RETAINER	52216		
8	NUT	52217		
9	PIVOT BOLT	52218-1		
10	LINK	52219A		
11	KNOB	52508		
12	SHIM	52986		

SEE PAGE 23 FOR ORDERING & DIMENSIONAL INFORMATION

HUSCO COMBINATION WORK PORT RELIEF AND ANTI-VOID UNIT

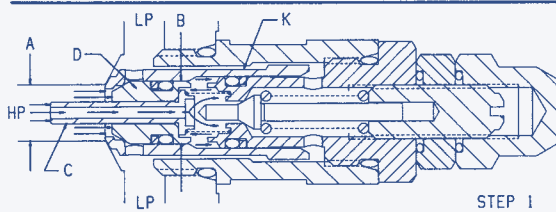

AS WORK PORT RELIEF

The relief valve is in communication between the high pressure port "HP" and low pressure "LP." Oil is admitted through the hole in poppet "C" and because of the differential area between diameters "A" and "B" relief valve poppet "D" and check valve poppet "K" are tightly seated as shown in the first step.

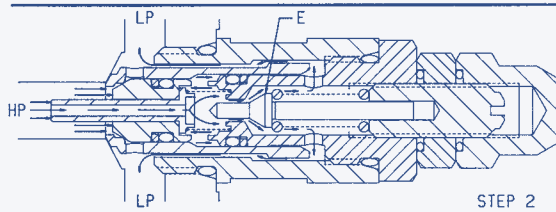

The oil pressure in the high pressure port "HP" has reached the setting of the pilot poppet spring force and unseats the pilot poppet "E." Oil flows around the poppet – through the cross drilled holes and to the low pressure area "LP."

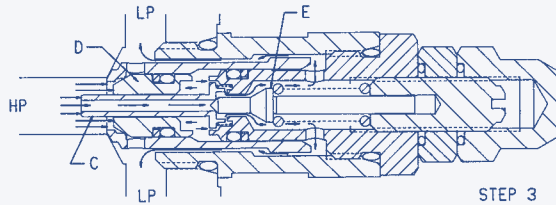

The loss of oil behind Poppet "C," effected by the opening of pilot poppet "E," causes poppet "C" to move back and seat against pilot poppet "E." This shuts off the oil flow to the area behind relief valve poppet "D," and causes a low pressure area internally.

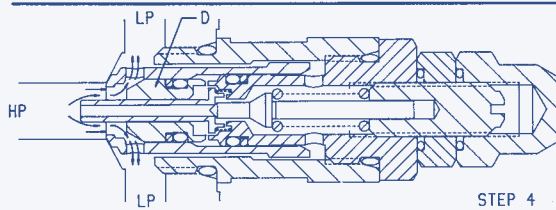

The imbalance of pressure on the inside, as compared to that of the high pressure port "HP," forces the relief valve poppet "D" to open and relieve the oil directly to the low pressure chamber "LP" in the valve.

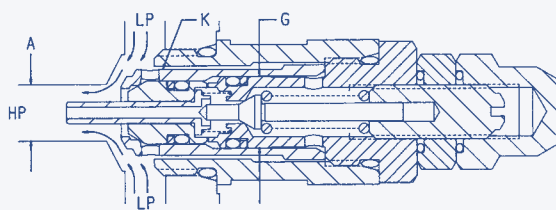

AS ANTI-VOID

The anti-void unit supplies oil to the high pressure port "HP" when cavitation has occurred. A lower pressure exists in the port "HP" compared to the low pressure chamber "LP." The difference between the effective area of diameter "A" and "G" causes imbalance of the check valve poppet "K" which unseats, thus allowing oil from the low pressure chamber "LP" to enter the port "HP" and fill the void.

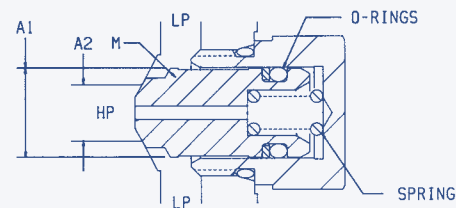

AS SEPARATE ANTI-VOID

The anti-void check valve opens when cavitation occurs in the high pressure port "HP" and supplies oil from the reservoir "LP" to help fill this void. The poppet "M" is held on its seat by the port pressure "HP," acting on the larger area behind the O-ring. When pressure "HP" drops below atmosphere, the tank pressure "LP" operating on the annular area A1-A2 will overcome the port pressure "HP" and the spring force to open the poppet. When the void is eliminated the spring will return the poppet which will then be tightly seated by the port pressure "HP."

Check HUSCO first for modern hydraulic/electrohydraulic components and systems engineered to your specific needs.

HUSCO COMBINATION WORK PORT RELIEF AND ANTI-VOID UNIT

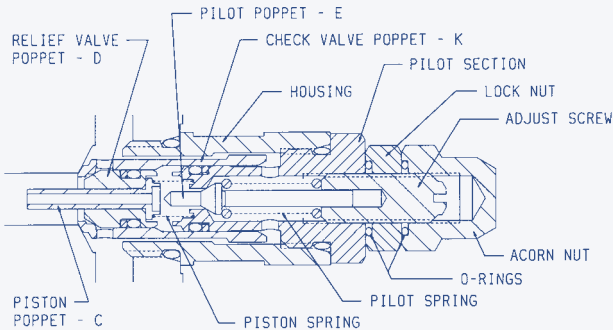

There are several variations to the Work Port Relief. However all are similar in nature regarding service and repair.

HOW TO SET PRESSURE ON WORK PORT RELIEF

A good pressure gage must be installed in the line which is in communication with the work port relief. A load must be applied in a manner to reach the set pressure of the port relief unit. Then, follow these steps:

- Remove acorn nut and loosen lock nut
- Set adjusting screw to desired pressure setting
- Tighten lock nut and reassemble acorn nut
- Retest in similar manner as above

The Void Control Feature is not adjustable but is designed to operate whenever the work port pressure is lower than the reservoir pressure.

SERVICE AND REPAIR INFORMATION

The cartridge type work port reliefs used in the HUSCO valves are typically of the pilot poppet type with external adjustment. Any malfunctioning is usually the result of foreign matter lodging between the piston, relief valve poppet and check valve.

To perform service, clean the surrounding area and remove the complete relief valve cartridge. Examine the seat in the main valve housing and if grooves or ridges are present, the valve must be returned to HUSCO for re-machining.

The design of the pilot poppet and its seat provides positive seating and very seldom requires any maintenance. Therefore, the pilot section can be removed from the cartridge housing without disturbing the setting. With it will come the check valve poppet and other internal parts. These are easily disassembled and should be examined for foreign matter. All seats and seating surfaces should be smooth and free of nicks, scratches or grooves. Examine O-rings and backup washers for any damage and replace if necessary. All moving parts should slide freely, with only seal friction being present.

After inspecting and cleaning, immerse all parts in hydraulic oil and reassemble. Since pressure setting was not disturbed, unit can be tested for proper functioning under actual working conditions.

If operating difficulties indicate that the pilot poppet is leaking or sticking, remove internal parts of the pilot section and follow the same procedure as above, plus follow "How to Set Pressure" previously discussed.

If unit still does not function properly, you may wish to return the cartridge to HUSCO.

DIFFICULTY	PROBABLE CAUSE	REMEDY
Can't get Pressure	Poppet D, E or K stuck open or contamination under seat.	Check for foreign matter between poppets D, E or K and their mating parts. Parts must slide freely.
Erratic Pressure	Pilot poppet seat damaged. Poppet C sticking in D.	Replace the relief valve. Clean and remove surface marks for free movement.
Pressure setting not correct	Normal wear. Lock nut & adj. screw loose.	See "How to set pressure on work port relief."
Leaks	Damaged seats. Worn O-rings. Parts sticking due to contamination.	Replace the relief valve. Install seal and spring kit. Disassemble and clean.

TROUBLE SHOOTING – ANTI-VOID

Trouble resulting in malfunctioning can usually be traced to foreign matter plugging and sensing hole or preventing free movement of poppet. Also check seat for scratches, nicks or other marks.

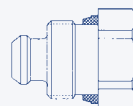

SHUT-OFF VALVE

Shut-off valves are available to fit most work port and main relief valve machining locations.

ASSEMBLY PROCEDURES FOR THE HUSCO 5000 VALVE

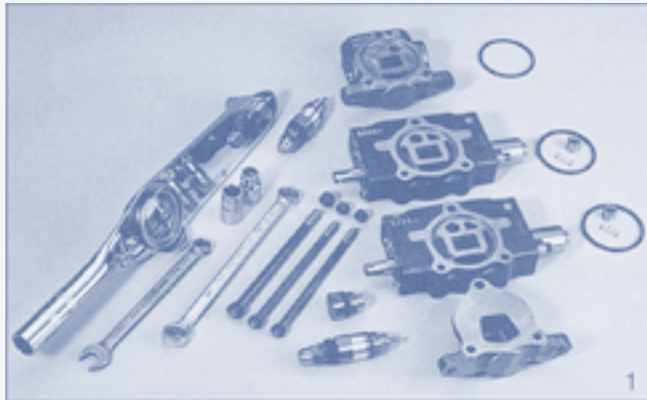

1. Lay out valve components on a clean, flat working surface. The inlet assembly will include an O-ring, and the spool section(s) include an O-ring, a load check poppet and a load check spring. Tools required for basic valve assembly include 1/2" and 9/16" open or box end wrenches and a torque wrench with thin wall sockets.

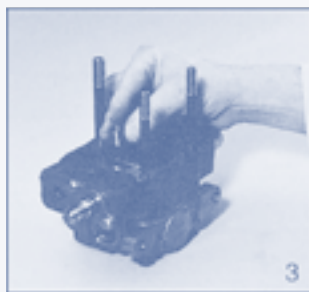

2. Assemble tie rod nuts to one end of each tie rod with one or two threads showing. Insert tie rods through tie rod holes of inlet (larger tie rod at top). Lay inlet on end with tie rods up, place O-ring into position.

3. Place first spool section (O-ring side up) on inlet section, position O-ring and insert load check poppet (nose down) and spring (behind poppet) into load check cavity as shown. Repeat this procedure for each spool section; the load check springs are compressed by the following sections during assembly.

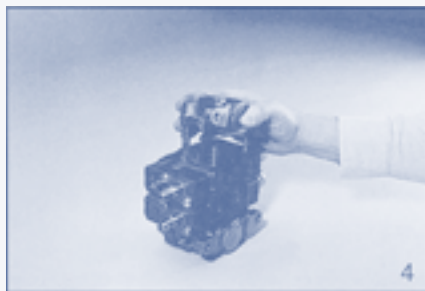

4. Position end section on last spool section as shown and hand tighten tie rod nuts. The end section is a "turn around" section without ports. Universal outlet/power beyond section and power beyond and closed center sections are also used as end sections. These end sections do not have O-ring grooves.



5. Position valve assembly with the mounting pads of the end sections on a flat surface. To obtain proper alignment of end sections relative to the spool sections, apply downward pressure to the end sections; snug tie rod nuts to about 10 ft-lb.

Final torque the two 1/2" nuts to 14 ft-lb; final torque the 9/16" nut to 33 ft-lb. Check for proper spool movement.

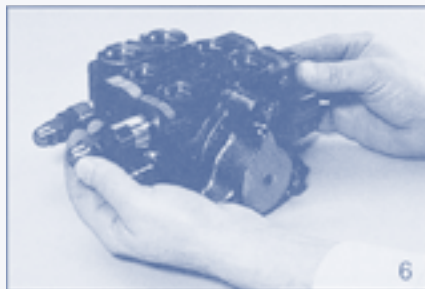

6. Install auxiliary valves and plugs and torque to proper specifications.

GENERAL ASSEMBLY NOTES:

A. Lever assemblies can be installed on section before or after complete valve assembly.

B. The load check and spring may be omitted from assembly in certain conditions (i.e., motor spools).

MODEL 5000 SECTIONAL VALVE ASSEMBLY SPECIFICATION SHEET

MODEL 5000 SECTIONAL VALVE ASSEMBLY SPECIFICATION SHEET					
CUSTOMER: _____		CUSTOMER P/N: _____			
MACHINE TYPE: _____		MACHINE MODEL: _____			
ESTIMATED ANNUAL USAGE: _____		SUBMITTED BY: _____		DATE: _____	
OPERATING PRESSURE: _____		INLET FLOW: _____		MID-INLET FLOW: _____	
			④ AUXILIARY VALVES		⑤ LEVERS
SECTIONS			AUX. "A"	AUX. "B"	ASSEMBLY P/N
①	INLET END COVER	5001- _____	P/N: _____ PSI: _____	INLET END COVER PORT PLUGS <small>SEE LISTING OF PLUG P/N'S BELOW</small> TOP IN: _____ TOP OUT: _____ END IN: _____ END OUT: _____	
OR MID-INLETS ② SPOOL SECTIONS	FUNCT: _____ TIE-ROD KIT 6131-1	500__ - _____	P/N: _____ PSI: _____	P/N: _____ PSI: _____	
	FUNCT: _____ TIE-ROD KIT 6131-2	500__ - _____	P/N: _____ PSI: _____	P/N: _____ PSI: _____	
	FUNCT: _____ TIE-ROD KIT 6131-3	500__ - _____	P/N: _____ PSI: _____	P/N: _____ PSI: _____	
	FUNCT: _____ TIE-ROD KIT 6131-4	500__ - _____	P/N: _____ PSI: _____	P/N: _____ PSI: _____	
	FUNCT: _____ TIE-ROD KIT 6131-5	500__ - _____	P/N: _____ PSI: _____	P/N: _____ PSI: _____	
	FUNCT: _____ TIE-ROD KIT 6131-6	500__ - _____	P/N: _____ PSI: _____	P/N: _____ PSI: _____	
	FUNCT: _____ TIE-ROD KIT 6131-7	500__ - _____	P/N: _____ PSI: _____	P/N: _____ PSI: _____	
	FUNCT: _____ TIE-ROD KIT 6131-8	500__ - _____	P/N: _____ PSI: _____	P/N: _____ PSI: _____	
	FUNCT: _____ TIE-ROD KIT 6131-9	500__ - _____	P/N: _____ PSI: _____	P/N: _____ PSI: _____	
	FUNCT: _____ TIE-ROD KIT 6131-10	500__ - _____	P/N: _____ PSI: _____	P/N: _____ PSI: _____	
③	OUTLET END COVER	5003- _____	P/N: _____ PSI: _____	OUTLET END COVER PORT PLUGS <small>SEE LISTING OF PLUG P/N'S BELOW</small> TOP P.B.: _____ TOP OUT: _____ END P.B.: _____ END OUT: _____	
COMMENTS: SAE PLUG ASSY P/N's: 6 SAE - 11120 8 SAE - 11150 10 SAE - 11180 12 SAE - 11210 TIE ROD TORQUE: LARGE DIA. 33 FT.LBS., SMALL DIA. 14 FT.LBS.					

CONTROL FOCUSED - TECHNOLOGY DRIVEN

For over 50 years, HUSCO International has been designing and producing some of the most important custom hydraulic and electrohydraulic products in the construction, forestry and material handling industry. Today HUSCO control products can be found on a variety of leading off-highway equipment including: Caterpillar, CNH, Crown, Daewoo, Deere & Company, Hyundai, JCB, Jerr-Dan, JLG, Komatsu, Kubota, Liebherr, Manitowoc Crane Group, NACCO, Volvo, Terex, just to name a few.

Dedicated to meeting and exceeding the changing control needs of the off-highway market for today and well into tomorrow, HUSCO employs an extensive engineering staff capable of designing customized, cost-effective solutions to maximize the efficiency, productivity, controllability and reliability of vehicles.

And with vehicle fit-up and testing capabilities, we're able to design, install and test valve configurations at HUSCO facilities, reducing product development time while optimizing vehicle performance through iterative testing.

With manufacturing facilities in North America, Europe and Asia, we continue to expand as we work with international partners in South America, Korea, Japan, India, South Africa and Australia to bring you any product you need, anywhere in the world.

TECHNOLOGY DRIVEN

CONTROL FOCUSED

HUSCO
INTERNATIONAL
control focused - technology driven

© 2005 HUSCO International

EUROPE

HUSCO International, Ltd.
6 Rivington Road
Whitehouse Industrial Estate
Runcorn, Cheshire WA7 3DT England
Telephone +44-1928-701888 | Fax +44-1928-710813

AMERICA

HUSCO International
W239 N218 Pewaukee Road
Waukesha, Wisconsin 53188 USA
Telephone +01-262-513-4200 | Fax +01-262-513-4427
www.huscointl.com

ASIA

HUSCO-Kayaba Hydraulics (Shanghai) Ltd.
No. 235 Jiangtian Road East
Song Jiang Industrial Zone
Shanghai 201600 China
Telephone +86-21-5774-6468 | Fax +86-21-3774-0186